



AirLink RV50 Series

Hardware User Guide



SIERRA
WIRELESS®

4117313
Rev 5

Important Notice

Due to the nature of wireless communications, transmission and reception of data can never be guaranteed. Data may be delayed, corrupted (i.e., have errors) or be totally lost. Although significant delays or losses of data are rare when wireless devices such as the Sierra Wireless modem are used in a normal manner with a well-constructed network, the Sierra Wireless modem should not be used in situations where failure to transmit or receive data could result in damage of any kind to the user or any other party, including but not limited to personal injury, death, or loss of property. Sierra Wireless accepts no responsibility for damages of any kind resulting from delays or errors in data transmitted or received using the Sierra Wireless modem, or for failure of the Sierra Wireless modem to transmit or receive such data.

Safety and Hazards

Do not operate the Sierra Wireless modem in areas where blasting is in progress, near medical equipment, near life support equipment, or any equipment which may be susceptible to any form of radio interference. In such areas, the Sierra Wireless modem **MUST BE POWERED OFF**. The Sierra Wireless modem can transmit signals that could interfere with this equipment.

The driver or operator of any vehicle should not operate the Sierra Wireless modem while in control of a vehicle. Doing so will detract from the driver or operator's control and operation of that vehicle. In some states and provinces, operating such communications devices while in control of a vehicle is an offence.

The RV50 Series platform is classified to ANSI/ISA 12.12.01-2016 and CSA C22.2#213 and are suitable for use in Class 1, Division 2, Groups A, B, C and D T4, and Class I Zone 2 Group IIC T4 classified Hazardous Locations.

The following warnings and instructions apply:

Warning: EXPLOSION HAZARD—SUBSTITUTION OF COMPONENTS MAY IMPAIR SUITABILITY FOR CLASS I, DIVISION 2 and CLASS I, ZONE 2.

Avertissement: RISQUE D'EXPLOSION-LA SUBSTITUTION DE COMPOSANTS PEUT RENDRE CE MATERIEL INACCEPTABLE POUR LES EMPLACEMENTS DE CLASSE I, DIVISION 2 et CLASSE I, ZONE 2.

Warning: EXPLOSION HAZARD—DO NOT DISCONNECT WHILE CIRCUIT IS LIVE UNLESS THE AREA IS KNOWN TO BE NON-HAZARDOUS.

Avertissement: RISQUE D'EXPLOSION-NE PAS DEBRANCHER TANT QUE LE CIRCUIT EST SOURS TENSION, A MOINES QU'IL NE S'AGISSE D'UN EMPLACEMENT NON DANGEREUX.

Warning: DO NOT USE THE USB CONNECTOR IN A HAZARDOUS AREA.

Avertissement: NE PAS UTILISER DE CONNECTEUR USB DANS LES ENVIRONNEMENTS DANGEREUX.

Warning: *DO NOT USE THE RESET BUTTON IN A HAZARDOUS AREA.*

Avertissement: *NE PAS UTILISER LE BOUTON DE RESET DANS UN ENVIRONNEMENT DANGEREUX.*

Limitation of Liability

The information in this manual is subject to change without notice and does not represent a commitment on the part of Sierra Wireless. SIERRA WIRELESS AND ITS AFFILIATES SPECIFICALLY DISCLAIM LIABILITY FOR ANY AND ALL DIRECT, INDIRECT, SPECIAL, GENERAL, INCIDENTAL, CONSEQUENTIAL, PUNITIVE OR EXEMPLARY DAMAGES INCLUDING, BUT NOT LIMITED TO, LOSS OF PROFITS OR REVENUE OR ANTICIPATED PROFITS OR REVENUE ARISING OUT OF THE USE OR INABILITY TO USE ANY SIERRA WIRELESS PRODUCT, EVEN IF SIERRA WIRELESS AND/OR ITS AFFILIATES HAS BEEN ADVISED OF THE POSSIBILITY OF SUCH DAMAGES OR THEY ARE FORESEEABLE OR FOR CLAIMS BY ANY THIRD PARTY.

Notwithstanding the foregoing, in no event shall Sierra Wireless and/or its affiliates aggregate liability arising under or in connection with the Sierra Wireless product, regardless of the number of events, occurrences, or claims giving rise to liability, be in excess of the price paid by the purchaser for the Sierra Wireless product.

Patents

This product may contain technology developed by or for Sierra Wireless Inc. This product includes technology licensed from QUALCOMM®. This product is manufactured or sold by Sierra Wireless Inc. or its affiliates under one or more patents licensed from MMP Portfolio Licensing.

Copyright

© 2019 Sierra Wireless. All rights reserved.

Trademarks

Sierra Wireless®, AirPrime®, AirLink®, AirVantage® and the Sierra Wireless logo are registered trademarks of Sierra Wireless.

Windows® and Windows Vista® are registered trademarks of Microsoft Corporation.

Macintosh® and Mac OS X® are registered trademarks of Apple Inc., registered in the U.S. and other countries.

QUALCOMM® is a registered trademark of QUALCOMM Incorporated. Used under license.

Other trademarks are the property of their respective owners.

Contact Information

Sales information and technical support, including warranty and returns	Web: sierrawireless.com/company/contact-us/ Global toll-free number: 1-877-687-7795 6:00 am to 5:00 pm PST
Corporate and product information	Web: sierrawireless.com

>> Contents

Introduction to the RV50 Series	8
Key Features	8
Description	10
Gateway Configuration and Management	11
Power Modes	11
Power Saving Features	11
Sample Power Consumption Scenarios	13
Dual SIM	13
Network Operator Switching	14
Accessories	14
Warranty	14
Specifications at a Glance	15
Certification and Interoperability	15
Mobile Network Operator Certification: RV50 (Pending for the RV50X)	15
RV50 Series Hardware and Software Specifications at a Glance	16
Environmental Testing	18
Installation and Startup	20
Tools and Materials Required	20
Installation Overview	20
Step 1—Insert the SIM Cards	21
Step 2—Connect the Antennas	22
Step 3—Connect the Data Cables	23
Step 4—Connect the Power	25
Cable Strain Relief	25
Fusing	26
DC Voltage Transients	26
Grounding the RV50 Series Gateway Chassis	26
Power Connector on the RV50 Series Gateway	27
Wiring Diagrams	29
I/O Configuration	31

Step 5—Check the gateway operation	38
LED Behavior	39
Ethernet LEDs	40
Step 6—Startup and Software Configuration	40
Configuring with AMM	42
Transitioning from a Raven Gateway	42
Step 7—Mounting the RV50 Series Gateway	43
Mounting Brackets	43
Flat Surface Mount	43
DIN Rail Mount	44
Reboot the RV50 Series Gateway	46
Reset the RV50 Series Gateway to Factory Default Settings	46
Recovery Mode	46
RV50 Series Specifications	48
Radio Frequency Bands	48
Radio Module Conducted Transmit Power	54
Carrier Aggregation Combinations	57
GNSS Technology	58
SIM Interface	59
Reliability Specifications	59
Mechanical Specifications	60
Power Specifications	61
Regulatory Information	62
Important Information for North American Users	62
RF Exposure	62
EU	63
Notice for Brazilian Users	64
Accessories	65
DC Power Cable (Black Connector)	65

AC Power Adapter (Black Connector)	66
AC Power Adapter Input	66
AC Power Adapter Output	66
AC Power Adapter Environmental Specifications	67
AC Power Adapter Reliability and Quality Control	67
AC Power Adapter Safety Standards	67
AC Power Adapter EMC Standards	68
AC Power Adapter Hazardous Substances	68
AC Power Adapter Energy Efficiency	68
Certified Antennas for Japan	68
Acronyms	69
Index	74

>> 1: Introduction to the RV50 Series

This hardware user guide is for the Sierra Wireless® AirLink® RV50 and the RV50X gateways. [Table 1-1](#) compares the two gateways. Features and specifications described in this user guide apply to both gateways unless otherwise noted.

Table 1-1: Product Comparison

Feature	RV50	RV50X
Supported Radio Frequency Band	LTE, with fallback to HSPA and CDMA	LTE-Advanced, with fallback to HSPA+
Maximum Data Throughput	100 Mbps	300 Mbps

The RV50 Series gateways are compact, intelligent and fully-featured communications platforms that provide real-time wireless capabilities for fixed and mobile applications. They are intended for use in industrial settings such as:

- Remotely monitoring and controlling infrastructure and surveillance equipment on pipelines, meters, pumps and valves in any energy, utility, or industrial application
- Tracking the location of heavy equipment and assets in the field
- Providing reliable Internet access to a mobile workforce

The RV50 Series gateway has multiple communication ports including serial, Ethernet, and USB ports. The power connector has one GPIO pin for remote monitoring and control and one ignition sense pin to turn the gateway on and off.

The RV50 is an LTE cellular gateway that supports a variety of radio band options, including 3G HSPA+ or CDMA EV-DO mobile broadband technology.

The RV50X is an LTE-Advanced cellular gateway that supports LTE and HSPA+ radio bands.

The RV50 Series gateways, with their rich feature set, configurable with the included ALEOS software, are the perfect choice for a broad set of IoT solutions.

Key Features

- High-performance LTE-Advanced support (RV50X only)
- LTE performance at 2G power consumption (less than 1 W in idle mode)
- State of the art LTE coverage:
 - RV50—11 LTE frequency bands
 - RV50X—21 LTE frequency bands
- Product variants:
 - RV50: Single product variant for all major North American operators
 - RV50X: Two variants —One for North America and Europe and one for Asia Pacific
- Fully automatic network operator switching; just insert the SIM card
- Provides network connectivity via Ethernet, Serial, and USB
- Gigabit Ethernet support (10/100/1000)
- Remote configuration, software update, and monitoring with AirLink Management Service (ALMS)

- Meets industrial-grade certifications including Class 1 Div 2, Class I Zone 2, MIL-STD-810G, IP64 ingress protection
- Supports up to 5 VPN tunnels to support secure communications over cellular networks
- Events engine for alert reporting to third party server platforms
- ALEOS Application Framework (AAF) offers real-time onboard data processing
- Built-in, class-leading voltage transient protection provides superior reliability and continuous operation
- E-Mark and SAEJ1455 for shock and vibration
- Active GNSS for tracking equipment
- Preprogrammed low voltage disconnect to prevent battery drain
- Security via Remote Authentication (RADIUS, TACACS+, LDAP) to centrally manage gateway access
- Industry leading warranty includes support, software updates, and advance replacement
- [Power Saving Features](#), including:
 - Processor Power Saving Mode
 - LED power saving mode
 - Standby mode
 - Power saving strategies such as turning off unused interfaces (USB, Serial, Ethernet), turning off GNSS, and adjusting the Ethernet data rate
- Multi-function digital input, analog input, switchable low side current sink, and high side configurable pull-up

For information on configuring these features, refer to the ALEOS Software Configuration User Guide.

Description

Back Panel

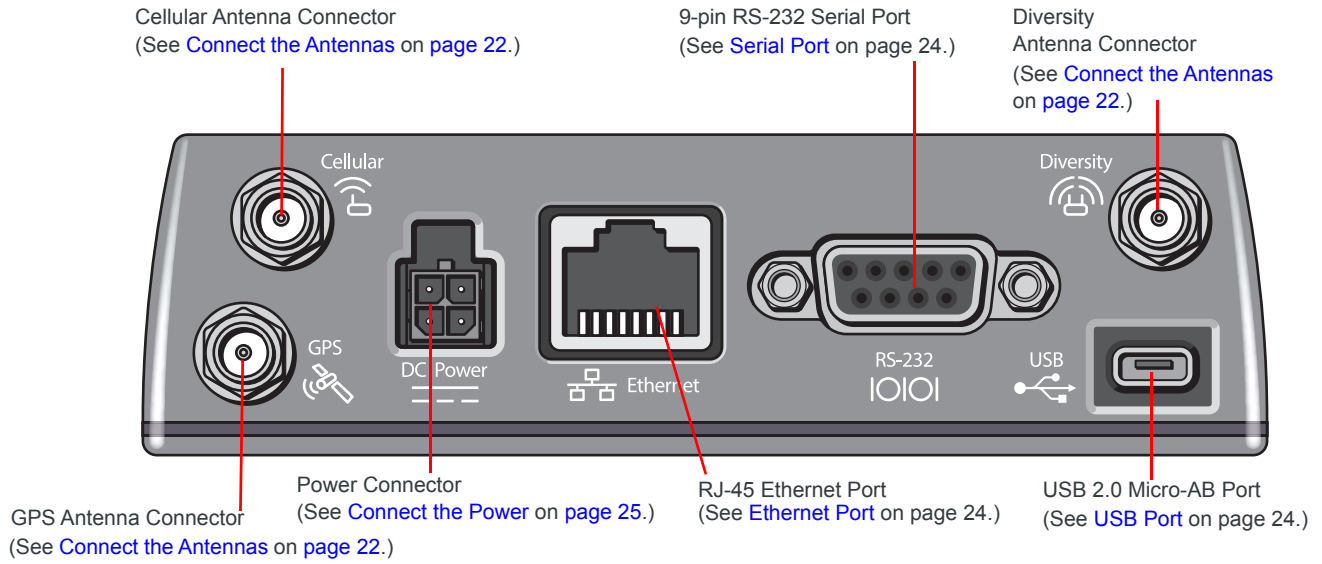

Front Panel

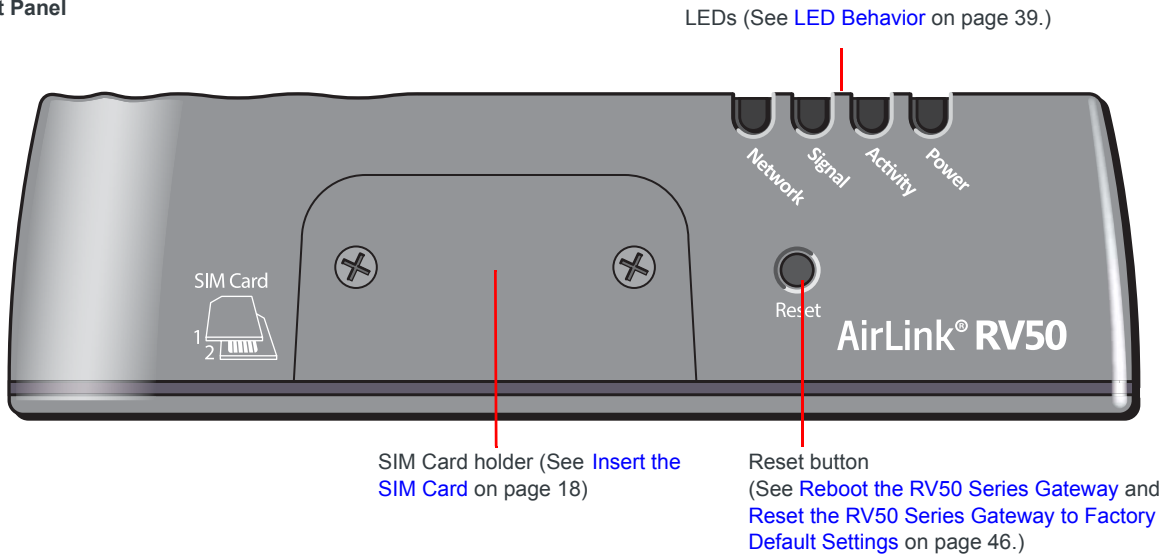

Figure 1-1: RV50 Series Gateway Connectors, LEDs and SIM Card Holder

Gateway Configuration and Management

You can configure and manage your RV50 Series gateway using:

- **ACEmanager**—a browser-based gateway management application
Refer to the ALEOS Software Configuration User Guide available for download at source.sierrawireless.com.
- **AirLink Management Service (ALMS)**—a cloud-based gateway management service provided by Sierra Wireless
For more information, visit www.sierrawireless.com/ALMS or contact your Sierra Wireless distributor.
- **AirLink Mobility Manager (AMM)**—a Network Management solution that provides a consolidated view of the entire vehicle fleet and enables simplified management, control and monitoring of connected AirLink routers.
- **AT Commands**
For a complete list of AT Commands, refer to the ALEOS Software Configuration User Guide.

Power Modes

The AirLink RV50 Series gateway has three power modes:

- **On**—The CPU and the radio are on. The current draw is 900 mW (75 mA @ 12 VDC) when the gateway is idle (i.e. no traffic is being sent or received).
- **Standby**—The CPU and the radio are off, but can be woken by an I/O input or at a configured time. Current draw is 53 mW (4.4 mA @ 12 VDC).
- **Off**—All power is switched off. Ignition is low, but Vin remains connected. Current draw is 11 mW (0.9 mA @ 12 VDC).

Power Saving Features

[Table 1-2](#) provides a quick reference to the RV50 Series power saving features. For more information, refer to the ALEOS Software Configuration User Guide.

If you are transitioning from a Raven XT or Raven XE to the RV50 Series gateway and require the RV50 Series gateway to operate with a comparable level of power consumption, see [Transitioning from a Raven Gateway](#) on page 42.

Table 1-2: Power Saving Features

Feature	Where to configure in ACEmanager	Notes
Processor Power Savings Mode	Services > Power Management	This feature optimizes idle power consumption. Recommended for customers who require the best power consumption efficiency, for example in battery or solar powered applications. Enabling this feature saves energy by reducing performance where possible.
LED Power Saving		In LED power saving mode: <ul style="list-style-type: none"> Signal LED is off when the signal strength is good or average, but still alerts you when there is no signal or a poor signal. Network LED is off when there is a network connection, but alerts you when the gateway is connecting to a network and when there is a problem with the network connection. For more details, see LED Behavior on page 39.
Disable USB Port	LAN > USB	
Disable Ethernet Port	LAN > Ethernet	
Set Ethernet Data Rate	LAN > Ethernet > Advanced	Ethernet data rates can be set to Auto, 100 Mbits, 10 Mbits. If your use case does not require a Gigabit Ethernet connection, choosing a slower rate results in substantial power savings. When set to 10 or 100 Mbits, both sides of the link must be set to the same fixed speed and duplex settings. If you are unable to ensure that both sides of the link have exactly the same fixed settings, it is best to use Auto.
Disable Serial Port	Serial > Port Configuration	
Disable GNSS	GPS > Global Settings	GNSS is disabled by default.
Ignition Shutdown Delay	Services > Power Management	If the RV50 Series gateway is installed in a vehicle, connect the ignition sense pin (Pin 3) on the DC power cable to the vehicle ignition and configure the RV50 Series gateway to shut down after a configured delay once the ignition is turned off.
Low Voltage Disconnect		The RV50 Series gateway enters standby mode when the voltage reaches a user-defined threshold to prevent excessive battery drain in battery-operated systems.
Standby (Time-based)		The RV50 Series gateway is in standby mode and automatically wakes up periodically, for example hourly or daily.
Standby (I/O-based)		The RV50 Series gateway is in standby mode and automatically wakes up on configured I/O input.

Sample Power Consumption Scenarios

Table 1-3: Power Consumption Scenarios

Scenario	Radio	Ethernet	Serial	USB	GNSS	Processor Power Saving Mode	LED Power Saving Mode	Power ^a
Standby Mode	—	—	—	—	—	—	—	53 mW (4.4 mA)
Low Power — Serial	Idle Attached	Disabled	Enabled	Disabled	Disabled	Enabled	Enabled	885 mW (73.7 mA)
Low Power — Ethernet	Idle Attached	10 BaseT Full duplex	Disabled	Disabled	Disabled	Enabled	Enabled	900 mW (75 mA)
Typical without Power Saving Features	Attached and connected (+20 dBm LTE)	100 BaseT Full duplex	Enabled Idle	Enabled Idle	Enabled Active antenna	Disabled	Disabled	3700 mW (308.3 mA)
RV50X Only — Maximum without Power Saving Features	Attached and connected (+23 dBm LTE-A)	1000 BaseT Full duplex (maximum throughput)	Enabled	Enabled	Enabled Active antenna	Disabled	Disabled	5500 mW (458.3 mA)
RV50 Only — Peak without Power Saving Features^b	Attached and connected (+32 dBm 1 up/ 1 down GSM/ GPRS/ EDGE bursts)	1000 BaseT Full duplex (maximum throughput)	Enabled	Enabled	Enabled Active antenna	Disabled	Disabled	8000 mW (666.6 mA)
Inrush Current	1.5 A @ 12 V (Averaged over 100 μ s)							

a. Power consumption was measured at 12 V.

b. Peak without power saving is similar to Maximum without power saving, but measured as a maximum burst over a limited time.

Dual SIM

The AirLink RV50 Series gateway has two SIM card slots. You can decide which slot is the Primary SIM card. When the gateway is powered on or reboots, it automatically connects to the network associated with the Primary SIM card. If no card is present in that slot, it connects to the network associated with the Secondary SIM card. If configured to do so, data usage is tracked independently on both SIM cards. SIM PIN configuration is also available for both SIM cards. This feature allows users to install SIM cards for two different network operators, use one SIM card initially and later change network operators by configuring the new SIM card to be the Primary SIM card.

Network Operator Switching

The North American AirLink RV50 Series gateway comes preloaded with multiple versions of radio module firmware. When the gateway is powered on, it checks the stored radio module firmware versions and automatically loads the appropriate version for the installed Primary SIM card onto the radio module. While Network Operator Switching is in progress, the LEDs sequentially flash green (green LED chase).

If there is no SIM card installed in the Primary SIM card slot, the gateway uses the firmware associated with the SIM card in the Secondary SIM card slot.

This feature, which is intended for North American products, makes it possible to use a single hardware variant on multiple operator networks.

Accessories

The following items come with the RV50 Series gateway:

- DC power cable
- Mounting screws
- Quick Start Guide

The following items can be ordered separately from Sierra Wireless:

- Universal AC power adapter
 - Voltage input: 100–240 VAC
 - Current output: 1.5 A
 - Part number: 2000492
- DIN rail mounting bracket (See [DIN Rail Mount](#) on page 44.)

Warranty

The RV50 Series gateway comes with a 3-year warranty, and has an optional 2-year warranty extension.

>> 2: Specifications at a Glance

This chapter gives a brief summary of RV50 Series gateway features.

For additional information see [RV50 Series Specifications](#) on page 48.

Certification and Interoperability

Emissions / Immunity	<ul style="list-style-type: none"> • CE (Including EMC Test case for vehicle installation EN302489) • ACMA RCM • FCC • Industry Canada
Safety	<ul style="list-style-type: none"> • CB Scheme • UL 60950
Industry Certification for Vehicles	<ul style="list-style-type: none"> • E-Mark (UN ECE Regulation 10.04), ISO7637-2 • SAE J1455 (Shock & Vibration)
Environmental Compliance	<ul style="list-style-type: none"> • RoHS 2011/65/EU (RoHS 2) • WEEE • REACH • Halogen-free PCB
Hazardous Environments	<ul style="list-style-type: none"> • Class 1 Div 2 and Class I Zone 2: C22.2 No. 213 (Canada) and ISA 12.12.01
GSM/UMTS Certifications	<ul style="list-style-type: none"> • PTCRB • GCF-CC • RED

Mobile Network Operator Certification: RV50 (Pending for the RV50X)

- Verizon Wireless
- AT&T
- Sprint
- T-Mobile USA
- US Cellular
- Rogers
- Bell
- Telus

RV50 Series Hardware and Software Specifications at a Glance

Table 2-1: Hardware and Software Specifications

Network Technology	See Radio Frequency Bands on page 48.
Host Interfaces	<ul style="list-style-type: none"> • 10/100/1000 Base-T RJ-45 Ethernet • RS-232 serial port • USB 2.0 Micro-AB connector • 3 SMA antenna connectors (LTE, Diversity, Active GNSS)
SIM Card Interface	Two mini-SIM (2FF) slots
Input/Output For more information, see page 33 .	Configurable I/O pin on power connector <ul style="list-style-type: none"> • Digital Input • High side configurable internal pull-up (to V_{in}) resistor • Analog input • Open collector output/low side sink
Power Adapter Pins	4-Pin connector: <ul style="list-style-type: none"> • Power • Ground • Configurable digital I/O and analog voltage input sensing • Configurable ignition sense
Reset	Manual reset button or using ACEmanager
LEDs	4 LEDs: <ul style="list-style-type: none"> • Network • Signal • Activity • Power
Mechanical Specifications For mechanical drawings, see Mechanical Specifications on page 60.	<ul style="list-style-type: none"> • 119 mm × 34 mm × 85 mm (94 mm including connectors) 4.69 in. × 1.34 in. × 3.35 (3.70 in. including connectors) • 320 g (11.3 oz.) • Housing—The RV50 Series gateway is made of ruggedized powder-coated aluminum. • RoHS—The RV50 series gateway complies with the Restriction of Hazardous Substances Directive (RoHS). This directive restricts the use of six hazardous materials in the manufacture of various types of electronic and electrical equipment.
Screw Torque Settings	<ul style="list-style-type: none"> • DIN rail mount screws (for attaching the RV Series to the DIN rail) 1.1 N-m (10 in-lb) • Antennas Finger tight (5–7in-lb.) is sufficient and the max torque should not go beyond 1.1 N-m (10 in-lb).
Operating Voltage	Input voltage: 7–36V Maximum ripple voltage to guarantee analog input accuracy: 100 mVpp

Table 2-1: Hardware and Software Specifications (Continued)

Power Consumption	See page 13 .
GNSS Technology For GNSS bias information, see GNSS Technology on page 58.	<ul style="list-style-type: none"> • Channels—Maximum 30 channels (16 GPS, 14 GLONASS), simultaneous tracking • Protocol—NMEA 0183 V3.0 • Acquisition time: <ul style="list-style-type: none"> • Hot start: 1 second • Warm start: 29 seconds • Cold start: 32 seconds <p>Measured with signal strength = -135 dBm</p> <ul style="list-style-type: none"> • Accuracy: <ul style="list-style-type: none"> • Horizontal: < 2 m (50%); < 5 m (90%) • Altitude: < 4 m (50%), < 8 m (90%) • Velocity: < 0.2 m/s • Tracking sensitivity: -160 dBm • Operational limits: Altitude < 6000 m or velocity < 360 km/h (223 mph) Either limit may be exceeded, but not both. • Datum: WGS84
Protocols	<ul style="list-style-type: none"> • Network: TCP/IP, UDP/IP, DNS • Routing: NAT, Host Port Routing, DHCP, PPPoE, VLAN, VRRP, Reliable Static Route • Applications: SMS, Telnet/SSH, Reverse Telnet, SMTP, SNMP, SNTTP, Reliable Static Routing • Serial: TCP/UDP PAD mode, Modbus (ASCII, RTU, Variable), PPP • GNSS: NMEA 0183 V 3.0, TAIP, RAP, Xora
Custom Applications	<p>Use ALEOS Application Framework (AAF) to develop your own applications to run on the RV50 and leverage the AirLink M2M Cloud platform.</p> <ul style="list-style-type: none"> • Lua language coding platform • Remote application management • Eclipse-based IDE • Integrated real-time debugging
VPN	<ul style="list-style-type: none"> • IPSec, GRE, and SSL Tunnel VPN clients • Up to 5 VPN tunnels • IKE encryption
Security	<ul style="list-style-type: none"> • Port Forwarding • Port Filtering • DMZ • Trusted IPs • MAC Filtering

Table 2-1: Hardware and Software Specifications (Continued)

Authentication	<ul style="list-style-type: none"> • LDAP • RADIUS • TACACS+
Events Reporting	<ul style="list-style-type: none"> • Event Types: digital input, GNSS/AVL, network parameters, data usage, timer, power, gateway temperature • Report types: SMS, email, SNMP trap, relay output, GNSS RAP reports, Events Protocol Message to Server

Environmental Testing

Test Method	Category	Description
MIL-STD-810G, Test method 514.6 IEC 60068-2-64	Vibration	Frequency range: 10 Hz–150 Hz Spectrum level: 2.24G on all axes for 8 hours/axis Operating mode: powered on
MIL-STD-810G, Test method 516.6	Mechanical Shock	Half-sine 40G, 15–23 ms, (+/-X, +/-Y, +/-Z directions, 10 times per axis) Operating mode: powered on
SAE J1455 for heavy-duty vehicles	Shock and Vibration	<ul style="list-style-type: none"> • Vibration: Section 4.10.4.2 Cab Mount • Shock: Section 4.11.3.4 Operational Shock
MIL-STD-810G, Test methods 501.5, 502.5	Temperature	Rugged category: -30 °C to 70 °C 2-hour soak each temp high/low 3 cycles ramp <= 3 °C/minute Operating mode: powered on
MIL-STD-810G, Test methods 501.5, 502.5	Temperature	Rugged category: -40 °C to 85 °C 2-hour soak each temp high/low 50 cycles ramp <= 3 °C/minute Operating mode: unpowered
MIL-STD-810G, Test method 507.5	Humidity	10 × 48-hour cycles: <ul style="list-style-type: none"> • 4-hour ramp to 60 °C (95% humidity), hold 8 hours • 4-hour ramp down to 30 °C (85% to 95% relative humidity), hold 21 hours • 1-hour ramp down to 20 °C, hold 4 hours • 1-hour ramp up to 30 °C, hold 5 hours Operating mode: powered on
IEC 60529	Water Resistance ^a	Subject to spraying water. Water sprayed at an angle up to 60° on either side of the vertical for 10 minutes. Operating mode: unpowered
IEC 61000-4-2	Electrostatic Discharge	+/-2 kV, +/-4 kV, +/-6 kV, +/-8 kV (Contact and Air) +/-15 kV (Air at antenna connector) Operating mode: powered on

Test Method	Category	Description
IEC 60068-2-32	Free Fall Test	1 m drop height 6 drops onto concrete, 2 per axis: X, Y, Z Operating mode: unpowered
IEC 60068-2-70 Part 2, Test Xb	Marking	The markings are rubbed with water for 10 cycles, then with lubricating oil for 10 cycles. Operating mode: unpowered
ISTA 2A 2001, test categories 1, 4, 5, & 6	Package	In shipping packaging. Cargo vibration and drop test.

- a. Ingress protection rating is IP64 (if RJ-45 ports are connected)

>> 3: Installation and Startup

This chapter shows how to connect, install and start the Sierra Wireless RV50 Series gateway. It also describes the front panel LEDs, and I/O functionality.

Note: Field wiring and connections in hazardous locations must be connected as per the wiring methods requirement for Class 2 circuits mentioned in the National Electric Code and the Canadian Electric Code.

Note: The RV50 Series gateway installation must be done by a qualified technician.

Tools and Materials Required

- Power supply — AC or DC (DC power cable is supplied by Sierra Wireless)
- A SIM card (provided by your mobile network operator)
- #1 Phillips screwdriver
- Laptop computer with Ethernet cable
- LTE MIMO antennas — Main and Diversity
- Optional—GPS antenna
- Optional—a 9-pin connection cable for the RS-232 port
- Optional—DIN Rail Mounting Bracket kit (available from Sierra Wireless)

Caution: *The gateway has a hardened case for use in industrial and extreme environments. If you are installing it in these types of environments, use cables designed and specified for use in these types of environments to avoid cable failure.*

Installation Overview

The steps for a typical installation are:

1. Insert the SIM card(s)—[page 21](#).
2. Connect the antennas—[page 22](#).
3. Connect the data cables—[page 23](#).
4. Connect the power—[page 25](#).
5. Check the gateway operation—[page 38](#).
6. Connect a laptop and configure ACEmanager—[page 40](#).
7. Mount the RV50 Series gateway—[page 43](#).

The following sections describe these steps in detail.

Note: Depending on where you are installing the RV50 Series gateway, you may want to mount the gateway before connecting the antenna, cables and power.

Step 1—Insert the SIM Cards

The AirLink RV50 Series gateway has two mini-SIM (2FF) card slots. The upper slot is Slot 1 and the lower slot is Slot 2. ACEmanager references these slot numbers, and by default, the SIM card in Slot 1 is the Primary SIM card. If you are using only one SIM card, Sierra Wireless recommends that you install it in Slot 1.

If the SIM card (or SIM cards) have not already been installed, insert the SIM cards into the gateway before connecting any external equipment or power to the gateway.

To install the SIM cards:

1. Use a #1 Phillips screwdriver to remove the SIM card cover.
2. Orient the SIM card(s), as shown in [Figure 3-1](#). The gold contacts on the upper SIM card face down, and the gold contacts on the lower SIM card face up. If you are using only one SIM card, insert it in the upper SIM slot (Slot 1).
3. Gently slide the SIM cards into the slots until they click into place.

To remove a SIM card, press the SIM card in, and release it. Gently grip the SIM card and pull it out.

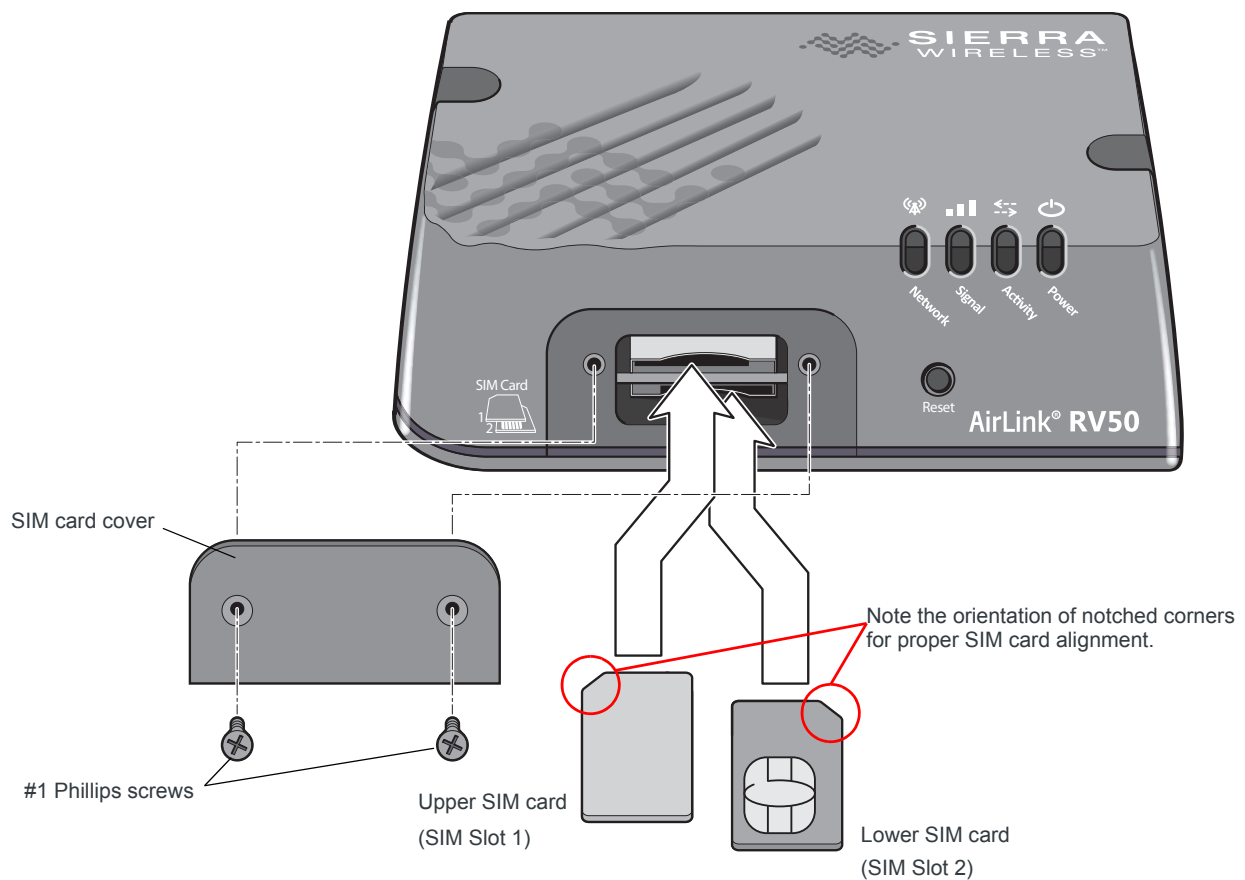

Figure 3-1: Installing the SIM Card

4. Replace the SIM card cover.

Step 2—Connect the Antennas

The RV50 Series gateway has three SMA female antenna connectors:

- Cellular Main antenna connector
- Cellular Diversity antenna connector: Required for 4G/LTE networks
- GPS antenna connector

For regulatory requirements concerning antennas, see [Maximum Antenna Gain](#) on page 63.

Note: The antenna should not exceed the maximum gain specified in [RF Exposure](#) on page 62. In more complex installations (such as those requiring long lengths of cable and/or multiple connections), you must follow the maximum dBi gain guidelines specified by the radio communications regulations of the Federal Communications Commission (FCC), Industry Canada, or your country's regulatory body.

To install the antennas:

Note: Take extra care when attaching the antennas to the SMA connectors. Finger tight (approximately 0.6–0.8 Nm/5–7 in-lb.) is sufficient and the max torque should not go beyond 1.1 Nm (10 in-lb.).

1. Connect the cellular antenna to the SMA cellular antenna connector.
Mount the cellular antenna so there is at least 20 cm between the antenna and the user or bystander.
2. Connect a second antenna to the SMA Diversity antenna connector.
For 3G networks, the second antenna operates as a diversity antenna, providing a second receive path.
For 4G networks, the second antenna operates as a MIMO antenna, providing a second receive path and a second transmit path.
3. If used, connect a GPS antenna to the SMA GPS antenna connector.
Mount the GPS antenna where it has a good view of the sky (at least 90°).

Note: ALEOS 4.7.0 and later is configured by default for an active GPS / GNSS antenna. If you are using a passive antenna, after the gateway is installed, launch ACEmanager, go to Location > Advanced and set the GNSS Antenna Bias field to Disable.

Note: If the antenna is located away from the gateway, keep the cables as short as possible to prevent the loss of antenna gain. Route the cables so that they are protected from damage and will not be snagged or pulled on. There should be no binding or sharp corners in the cable routing. Excess cabling should be bundled and tied off. Make sure the cables are secured so their weight will not loosen the connector from the gateway over time.

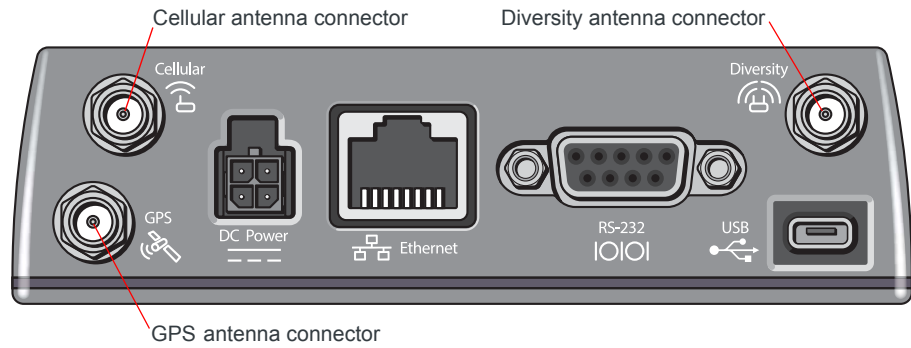

Figure 3-2: Antenna Connectors

Table 3-1: Recommended Antenna Separation

Service	Frequency (MHz)	Wavelength (λ) (mm)	Best Antenna Separation (mm) ($1/2 \lambda$)	Good Antenna Separation (mm) ($1/4 \lambda$)
LTE	700	428	214	107
LTE	800	375	187	94
LTE	900	333	167	83
LTE	1800	167	83	42
LTE	2100	143	71	36
LTE	2600	115	58	29
WCDMA	850	353	176	88
WCDMA	900	333	167	83
WCDMA	1900	158	79	39
WCDMA	2100	143	71	36
CDMA/EV-DO	800	375	187	94
CDMA/EV-DO	1900	158	79	39
GSM/GPRS/EDGE	850	353	176	88
GSM/GPRS/EDGE	900	333	167	83
GSM/GPRS/EDGE	1800	167	83	42
GSM/GPRS/EDGE	1900	158	79	39

Step 3—Connect the Data Cables

The RV50 Series gateway has three ports for connecting data cables:

- **USB Port** (Micro-AB)
- Use a Cat 5e or Cat 6 Ethernet cable to connect the **Ethernet Port** (RJ-45)
- **Serial Port** (9-pin RS-232)

USB Port

Warning: *Do not use the USB port in a potentially explosive environment.*

- Complies with USB Version 2.0 for high speed operation
- Can be configured to operate in one of two modes:
 - **Virtual Ethernet Port:** The RV50 Series gateway behaves as if the PC were connected to an Ethernet port, allowing access to the Internet and the gateway's internal web server. This is the default setting.
 - **Virtual Serial Port:** The RV50 Series gateway behaves as if it was connected to a standard serial port. The primary use of this interface is for the AT command line interface of ALEOS and for diagnostic access to the radio module.

A Windows driver must be installed on the PC in order to support USB virtual serial port mode. You can download the drivers from source.sierrawireless.com/resources/airlink/software_downloads/airlink_usb_driver/

For information about setting the USB mode and installing the USB driver, see the ALEOS Software Configuration User Guide.

Sierra Wireless recommends you:

- Use a USB 2.0 cable
- Connect directly to your computer for best throughput.

Ethernet Port

- IEEE 802.3 Ethernet specification for 1000 Mbps speed (Gigabit Ethernet) with fallback to 100 or 10 Mbps (Cat 5e or Cat 6 cable is required for Gigabit Ethernet)
- Auto-crossover support
- Auto-negotiation detects the speed of the connecting device for 1000 baseT, 100 baseT, or 10 baseT

Serial Port

- 9-pin serial port connects directly to most computers or other devices with a standard serial straight-through cable

Note: If you have a DCE device, you need to use a null modem (cross-over) cable.

- Used for connecting serial devices and configuration
- Complies with the EIA RS-232D specification for DCE equipment
- Output driver levels swing from -7 VDC to +7 VDC with normal loading

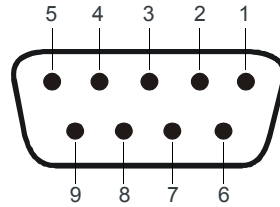

Figure 3-3: DB-9 Female Serial Connector

Table 3-2: Serial Connector Pin-out

Name	Pin	Description	Type
DCD	1	Data Carrier Detect	OUT
RXD	2	Receive Data	OUT
TXD	3	Transmit Data	IN
DTR	4	Data Terminal Ready	IN
GND	5	Main GND. Connected internally to BOARD GND	GND
DSR	6	Data Set Ready	OUT
RTS	7	Ready To Send	IN
CTS	8	Clear To Send	OUT
RI	9	Not connected	—

Step 4—Connect the Power

The AirLink RV50 Series gateway comes with a 3 meter (10 ft.) DC power cable. You can also purchase an optional AC adapter.

Note: Electrical installations are potentially dangerous and should be performed by personnel thoroughly trained in safe electrical wiring procedures.

The RV50 Series gateway supports a voltage range between 7 V and 36 V, but since low voltage standby mode is enabled by default (as of ALEOS 4.5.2), you must supply greater than 9 volts at startup.

If you want to operate the gateway at a lower voltage, change the low voltage settings once the gateway is up and running. For more information, refer to the ALEOS Software Configuration User Guide (Services chapter).

Cable Strain Relief

Sierra Wireless recommends using cable strain relief for installations in high-vibration environments.

Place the cable strain relief within 200 mm (8 in.) of the RV50 Series gateway to reduce the mass of cable supported by the power connector under vibration. Ideally, the strain relief mounting for the DC cable should be attached to the same

object as the gateway, so both the gateway and cable vibrate together. The strain relief should be mounted such that it does not apply additional stress on the power connector, i.e. the cable should not be taut and should not pull the power connector at an angle.

Fusing

For DC installations, Sierra Wireless recommends fusing the power input using a 4.0 A fast-acting fuse.

DC Voltage Transients

The AirLink RV50 Series gateway has built-in protection against vehicle transients including engine cranking (down to 5.0 V) and load dump, so there is no need for external power conditioning circuits. For details, see [Industry Certification for Vehicles](#) on page 15.

Grounding the RV50 Series Gateway Chassis

The RV50 should be mounted in accordance with accepted after-market practices and materials.

Mount the gateway where:

- There is easy access for attaching the cables
- Cables will not be constricted, close to high amperages or exposed to extreme temperatures
- The front panel LEDs are easily visible
- There is adequate airflow
- It is away from direct exposure to the elements, such as sun, rain, dust, etc.

The RV50 has 2 mounting holes, as shown in [Figure 3-4](#). Use the mounting screws and washers that came with the RV50 to secure it in place.

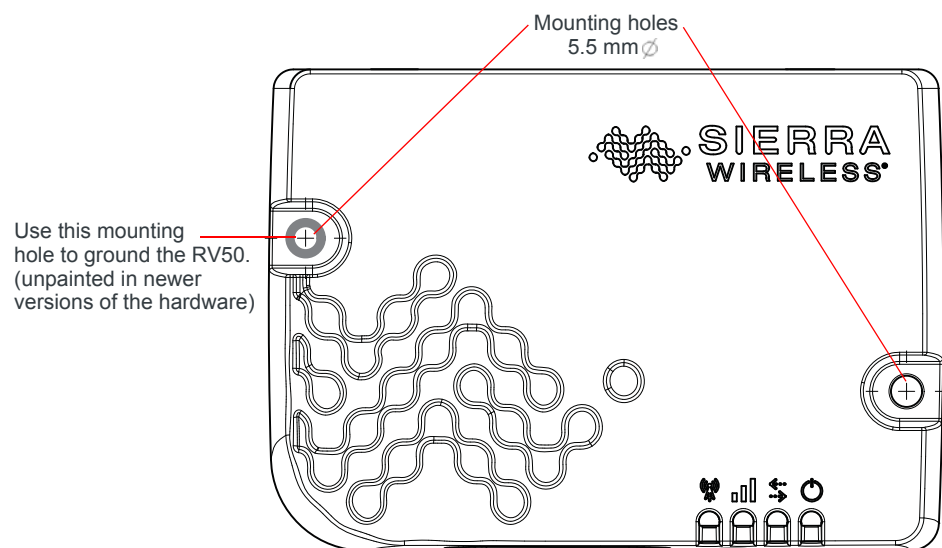

Figure 3-4: Mounting and Grounding the RV50

For DC installations (with a fixed “system” ground reference), Sierra Wireless strongly recommends always grounding the RV50 chassis to this system ground reference.

To ensure a good grounding reference, either:

- Attach the RV50 to a grounded metallic surface.
- Connect one end of a short 18 AWG or larger gauge wire to the unpainted upper left mounting hole (see [Figure 3-4](#)) and connect the other end to the system ground reference or (if mounted in a vehicle) the vehicle chassis.

Note: In some gateways the upper left mounting hole is painted. If you use the mounting screw and washer included with your gateway, this mounting hole still provides an effective ground, as the washer removes enough paint to allow contact between the wire and the metal chassis.

Power Connector on the RV50 Series Gateway

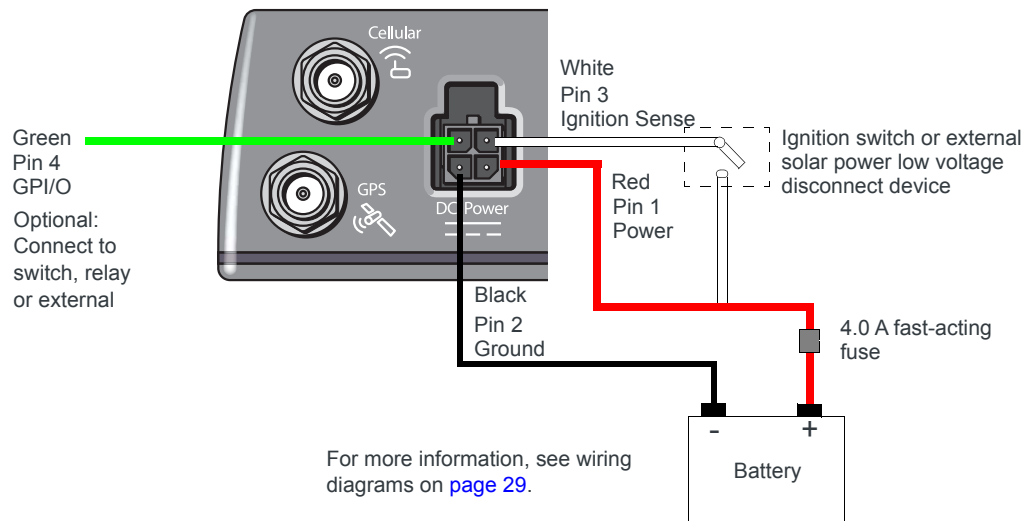

Figure 3-5: DC Power Cable Connections (Colors indicate DC cable wire colors.)

Table 3-3: Power Connector Pin and DC Cable Wires

Pin	Name	Associated DC Cable Wire Color	Description	Type
1	Power	Red	Main power supply for device <i>Note: When the gateway switches to Low Power mode based on a Low Voltage trigger, the voltage is monitored on the Red, Power wire.</i>	PWR
2	Ground	Black	Main device ground	PWR

Table 3-3: Power Connector Pin and DC Cable Wires

Pin	Name	Associated DC Cable Wire Color	Description	Type
3	Ignition Sense	White	<p>Sierra Wireless recommends using the Ignition Sense wire to turn the gateway off. It should not be turned off by disconnecting the power.</p> <hr/> <p><i>Note: If you do not connect pin 3 to the ignition, you MUST connect it to the positive terminal of your power supply or battery. If you are using a Sierra Wireless AC adapter, the connection is inside the cable.</i></p> <hr/> <p>For installations where the gateway is turned on/off, use the white wire in the DC cable connected to Pin 3 to:</p> <ul style="list-style-type: none"> • Turn the gateway on/off with the vehicle ignition <hr/> <p><i>Note: To turn the gateway on/off with the vehicle ignition, Sierra Wireless strongly recommends using an unswitched VCC on Pin 1 (Red, Power wire on DC cable) with Pin 3 (White, Ignition sense wire on DC cable) connected to the ignition.</i></p> <hr/> <ul style="list-style-type: none"> • Turn the gateway on/off with a low voltage disconnect device <hr/> <p><i>Note: For solar applications, if you want the gateway to turn off when the voltage drops below a defined level, connect Pin 3 to an external low voltage disconnect.</i></p> <hr/>	I
4	GPIO	Green	<p>User configurable digital input/output or analog voltage sensing input. Connect to switch, relay or external device. For more information, see I/O Configuration on page 31 and the ALEOS Software Configuration User Guide.</p>	I/O

Wiring Diagrams

Recommended Vehicle Installation

For vehicle installations, Sierra Wireless recommends connecting the white Ignition Sense wire to the vehicle's ignition switch, as shown in the following illustration.

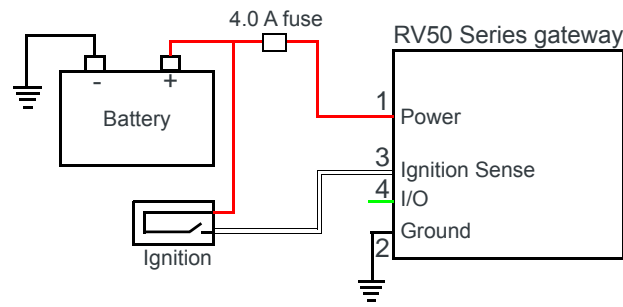

Figure 3-6: Recommended Vehicle Installation

The recommended vehicle installation allows the gateway to operate with the vehicle. When the vehicle ignition is off, the gateway is off. If desired, you can configure a delay between the time the vehicle's ignition shuts off, and the time the gateway shuts down. A delayed shutdown is especially useful if you want to maintain a network connection while the vehicle's engine is shut off for short periods, such as in a delivery vehicle.

- Pin 1 (Power)—Use the red wire in the DC cable to connect Pin 1 to the power source. Include a 4.0 A fast-acting fuse in the input power line. Sierra Wireless recommends using a continuous (unswitched) DC power source.
- Pin 2 (Ground)—Use the black wire in the DC cable to connect Pin 2 to ground. See also [Grounding the RV50 Series Gateway Chassis](#) on page 26.
- Pin 3 (Ignition Sense)—Sierra Wireless recommends always using the Ignition Sense wire (Pin 3) to turn the gateway off. It should not be turned off by disconnecting the power.

Alternate Vehicle Installation

The main difference between this installation and the standard vehicle installation is that you can configure a timer to turn the gateway on at set intervals for a configured length of time; for example 20 minutes once every 24 hours when the ignition is off. Also, instead of the gateway turning on and off, the gateway alternates between on and standby mode.

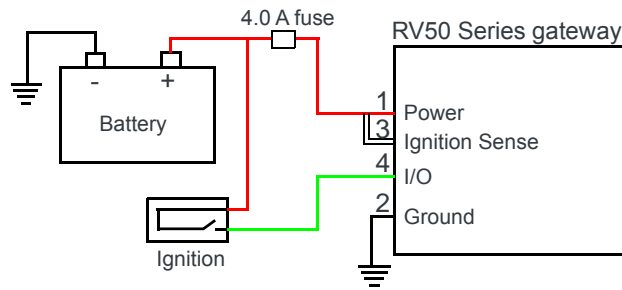

Figure 3-7: Alternate Vehicle Installation

- Pin 1 (Power)—Use the red wire in the DC cable to connect Pin 1 to the power source. Include a 4.0 A fast-acting fuse in the input power line. Sierra Wireless recommends using a continuous (unswitched) DC power source.
- Pin 2 (Ground)—Use the black wire in the DC cable to connect Pin 2 to ground. See also [Grounding the RV50 Series Gateway Chassis](#) on page 26.
- Pin 3 (Ignition Sense)—Connected to power
- Pin 4 (I/O)—Connected to ignition

Fixed Installation

For fixed installations, connect the wires as shown in the figure below. You can configure Low voltage disconnect to force the gateway into Standby mode when the voltage is low.

Note: When the gateway switches to Low Power mode based on a Low Voltage trigger, the voltage is monitored on the Red, Power wire.

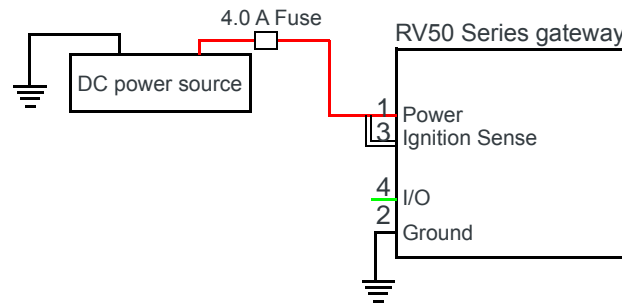

Figure 3-8: Fixed Installation without I/O

- Pin 1 (Power)—Use the red wire in the DC cable to connect Pin 1 to the power source. Include a 4.0 A fast-acting fuse in the input power line. Sierra Wireless recommends using a continuous (unswitched) DC power source.
- Pin 2 (Ground)—Use the black wire in the DC cable to connect Pin 2 to ground. See also [Grounding the RV50 Series Gateway Chassis](#) on page 26.
- Pin 3 (Ignition Sense)—Connected to power

Fixed Installation with I/O Input Triggered by Standby Mode

If you have a fixed installation where you want to use the I/O to monitor an external device such as a motion detector, remote solar panel, or a remote camera, refer to [Figure 3-9](#). You can configure the I/O line to wake the gateway up for a configured length of time, and use Low voltage disconnect to put the gateway in Standby mode if the voltage falls below a configured value.

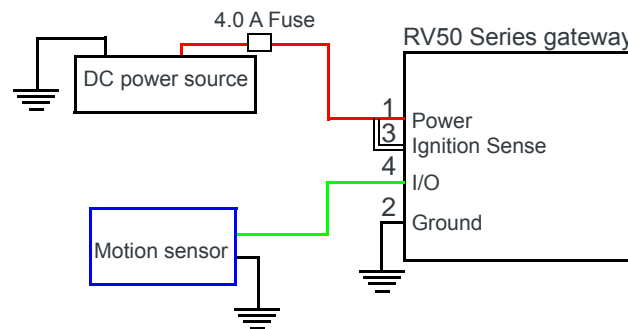

Figure 3-9: Fixed Installation with I/O

- Pin 1 (Power)—Use the red wire in the DC cable to connect Pin 1 to the power source. Include a 4.0 A fast-acting fuse in the input power line. Sierra Wireless recommends using a continuous (unswitched) DC power source.
- Pin 2 (Ground)—Use the black wire in the DC cable to connect Pin 2 to ground. See also [Grounding the RV50 Series Gateway Chassis](#) on page 26.
- Pin 3 (Ignition Sense)—Connected to power
- Pin 4 (GPIO)—Use the green wire for I/O configurations. See [I/O Configuration](#).

I/O Configuration

You can use the Pin 4 (GPIO) green wire as:

- A pulse counter
(See [Table 3-4](#) on page 33 and [Figure 3-10](#) on page 33.)
- A digital input
(See [Table 3-4](#) on page 33 and [Figure 3-11](#) on page 34.)
- A high side pull-up/dry contact switch input
(See [Table 3-6](#) on page 35 and [Figure 3-12](#) on page 35.)
- An analog input
(See [Table 3-7](#) on page 36 and [Figure 3-13](#) on page 36.)
- A low side current sink
(See [Table 3-8](#) on page 37 and [Figure 3-15](#) on page 37.)
- A digital output/open drain
(See [Table 3-9](#) on page 38 and [Figure 3-16](#) on page 38.)

For more information, refer to the ALEOS Software Configuration User Guide.

Note: You can configure the GPIO Pin 4 in ACEmanager or ALMS to trigger standby mode, to sink current, or to pull up the voltage. If you are using the I/O line to trigger standby mode, you cannot configure it to sink current or pull up the voltage. Likewise, if you are using the I/O line to either sink current or pull up the voltage, you cannot use it to trigger standby mode.

Note: During bootup, the I/O settings remain in their default state: the internal pull-up resistor is disabled, and output current sink switch is open. After bootup, any custom I/O settings are applied. This may take approximately 30 seconds after the gateway is restarted or powered on.

You can use Pin 4 in conjunction with events reporting to configure the RV50 Series gateway to send a report when the state of the monitored gateway changes, for example when a switch is opened or closed. For more information, refer to the ALEOS Software Configuration User Guide (Events Reporting chapter).

Pulse Counter

You can use the green wire to connect Pin 4 to a pulse counter. The digital pulse counter is not available in Standby mode.

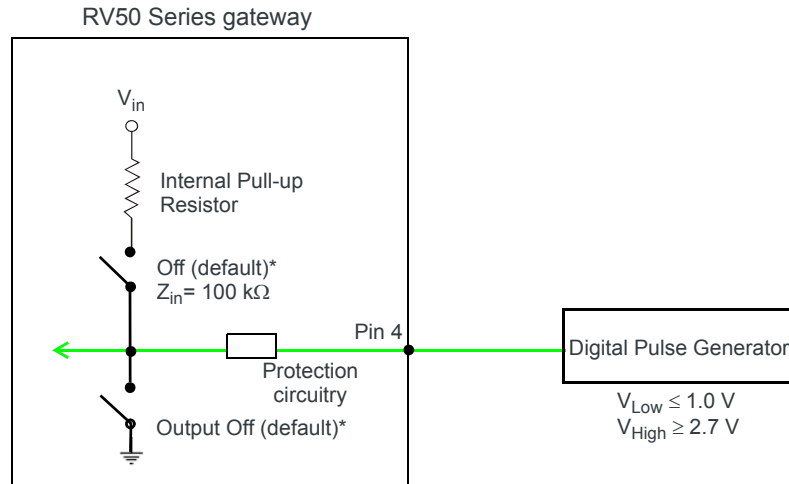

* Configurable on the ACEmanager I/O tab

Maximum frequency = 140 Hz

Duty cycle:

- Minimum = 20%

- Maximum = 80%

Note: values may vary, depending on signal noise.

Figure 3-10: Digital Input / Pulse Counter

Table 3-4: Pulse Counter

Pull-up	State	Minimum	Typical	Maximum	Units
Off	Low	—	—	1.0	V
	High	2.7	—	V_{in}	V

Digital Input

You can use the green wire to connect Pin 4 to a digital input to detect the state of a switch such as a vehicle ignition, or to monitor an external device such as a motion detector, a remote solar panel, or a remote camera. Digital input can also be used with the standby timer.

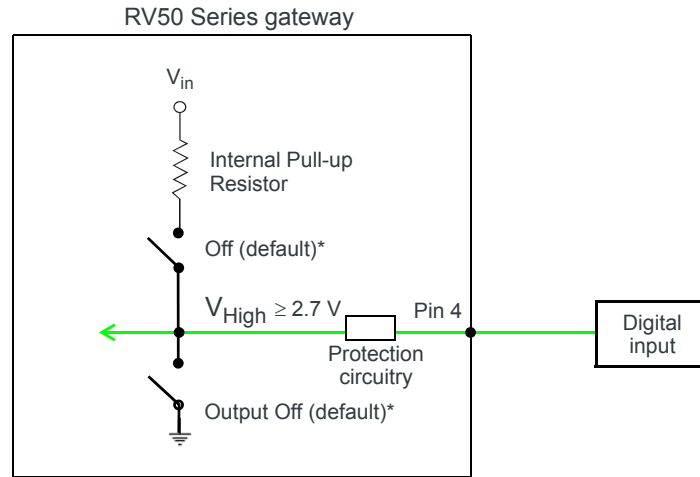

* Configurable on the ACEmanager I/O tab

Figure 3-11: Digital Input

Table 3-5: Digital Input

Pull-up	State	Minimum	Typical	Maximum	Units
Off	Low	—	—	1.0	V
	High	2.7	—	V_{in}	V

High Side Pull-up / Dry Contact Switch Input

You can use the green wire to connect Pin 4 to a dry contact switch. The dry contact switch is not available in Standby mode.

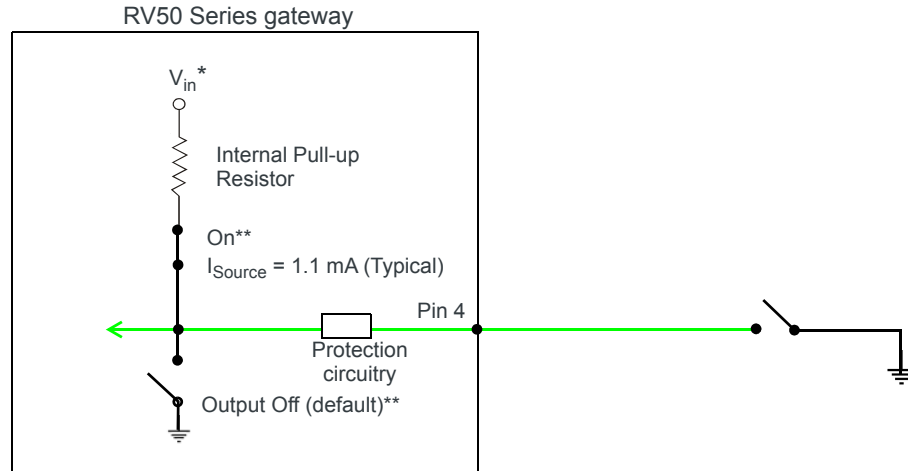

* Depending on the load, this value can range from V_{in} to $V_{in} - 2.5 \text{ V}$.

** Configurable on the ACEmanager I/O tab

Figure 3-12: High Side Pull-up / Dry Contact Switch Input

Table 3-6: High Side Pull-up / Dry Contact Switch Input

	Minimum	Typical	Maximum	Units	Comments
Source Current	0.6 $V_{in} = 7 \text{ V}$	1.1 $V_{in} = 12 \text{ V}$	3.5 $V_{in} = 36 \text{ V}$	mA	Maximum current the voltage output can provide (depends on V_{in})
V_{out}	$V_{in} - 2.5$	—	V_{in}	V	The voltage on Pin 4 when the high side pull-up is enabled (depends on V_{in} and power consumption)

Analog Input

You can use the green wire to connect Pin 4 to an analog sensor. As an analog input (voltage sensing pin), the gateway monitors voltage changes in small increments. This allows you to monitor equipment that reports status as an analog voltage.

Pin 4 detects inputs of 0.5–36 V referenced to ground. When used with a sensor to transform values into voltages, the pin can monitor measurements such as temperatures, sensors, or input voltage.

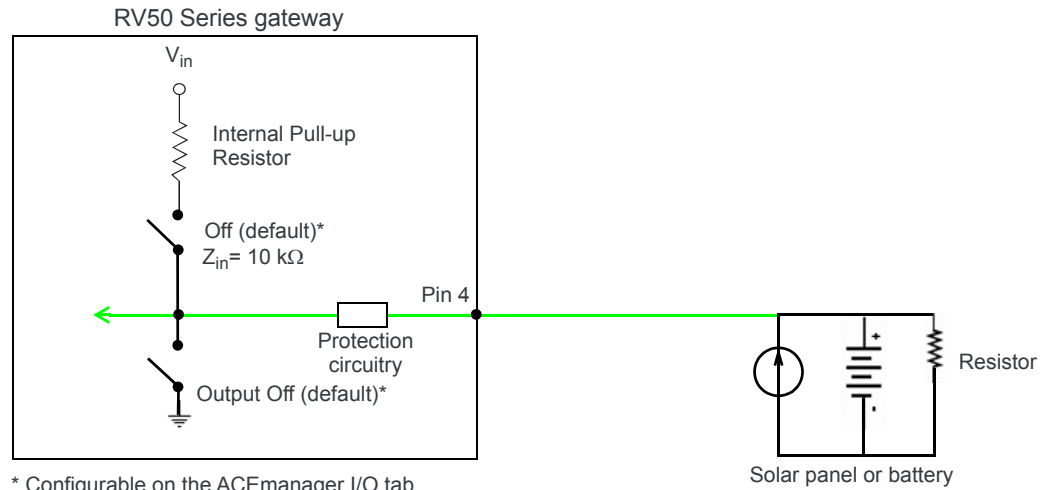

* Configurable on the ACEmanager I/O tab

Figure 3-13: Analog Input

Table 3-7: Analog Input

Pull-up		Minimum	Typical	Maximum	Units	Comments
Off	Analog Input Range	0.5	—	36	V	—
	Analog Input Accuracy	-1.5%	0.50%	1.5%	—	—

Data sampling is handled by a dedicated microprocessor. In order to filter noisy signals, twenty measurements are taken over a 250 ms interval and they are averaged to generate a sample. If the change since the last sample is significant, a notification is sent to the CPU for updating the current value displayed in the user interface and for use by Events Reporting.

Changes are considered significant if the change is 150 mV or more. If there has not been a significant change to the parameter being monitored, the CPU reads a sample every 2.5 minutes, which detects small changes.

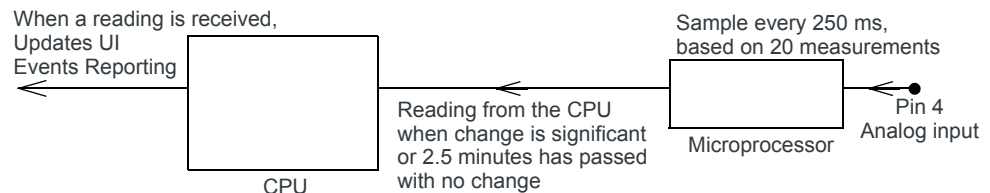
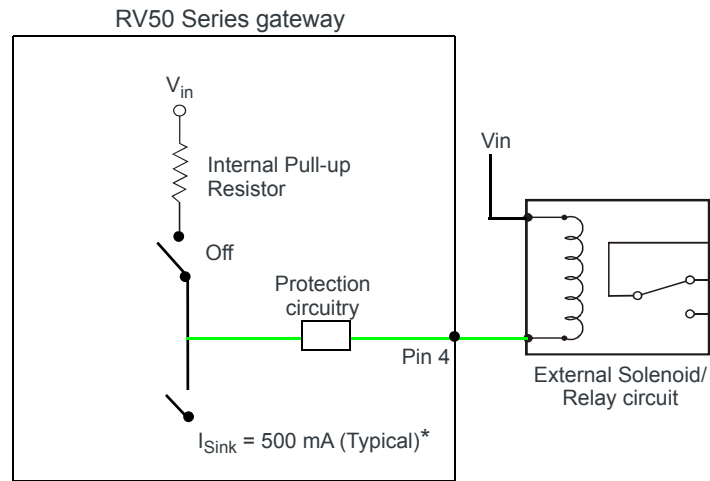

Figure 3-14: Analog Input Sampling and Reading

Note: The same method is used to sample the input voltage and the internal board temperature for Events Reporting. The significant changes are 300 mV for the input voltage and 1 °C for the board temperature.

Low Side Current Sink Output

You can use Pin 4 as a low side current sink, for example, to drive a relay.



* See Table 3-8 on page 37 for more details.

Figure 3-15: Low Side Current Sink

Table 3-8: Low Side Current Sink

Pull-up	State	Minimum	Typical	Maximum	Units	Comments
Off	On	250	500	1000	mA	$I_{\text{Typical}} = 25^{\circ}\text{C}$ $I_{\text{Min}} = 70^{\circ}\text{C}$ $I_{\text{Max}} = -40^{\circ}\text{C}$
Off	Off	—	0	—	mA	$V_{in} = 12$

Note: The gateway protection circuitry has a high-impedance ($\sim 125 \text{ k}\Omega$) path to ground. If Pin 4 is connected to 12 V, there will be a small current flow ($\sim 100 \mu\text{A}$) into Pin 4 during bootup. This flow is countered when the internal pull-up resistor ($10 \text{ k}\Omega$) becomes active after bootup. Depending on your application, you may need to install an external pull-up resistor ($10 \text{ k}\Omega$) in order to nullify the small input current flow for the first 30 seconds during bootup.

Digital Output/Open Drain

You can use Pin 4 as an open drain to drive an external digital input

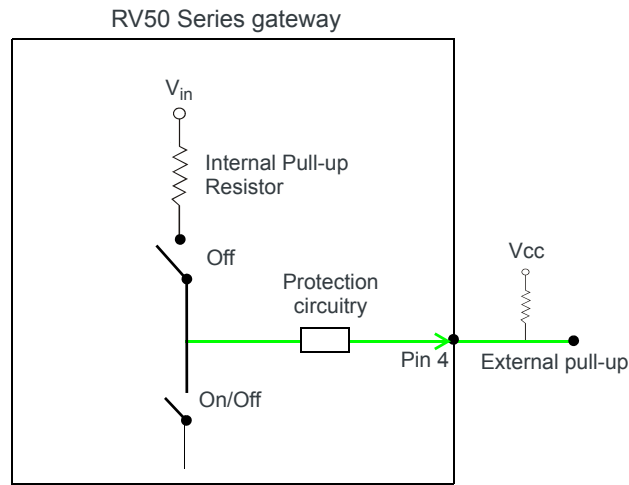

Figure 3-16: Digital Output/Open Drain

Table 3-9: Digital Output / Open Drain

Pull-up	State	Minimum	Typical	Maximum	Units	Comments
Off	Off	Open Circuit	—	—	—	—
	Active Low	—	—	0.5	V	5 mA, ≤ 5 V

Step 5—Check the gateway operation

- When power is supplied to the AirLink RV50 Series gateway, it powers up automatically, as indicated by the flashing LEDs. If it does not turn on, ensure that the:
 - Power connector is plugged in and supplying voltage between 7–36 V.

Note: Although the RV50 Series gateway operates in the range 7–36 V, low voltage standby mode is enabled by default (as of ALEOS 4.5.2), so in order to avoid the gateway powering into standby mode, ensure that it is supplied with more than 9 V at startup. (If desired, you can change the low voltage standby settings once the gateway is operational.) If the Power LED is red, the gateway is in standby mode.

- Ignition Sense (pin 3) is connected to the battery or power source (see [Step 4—Connect the Power](#) on page 25 for details)

LED Behavior



Figure 3-17: LED location

Table 3-10: LED Behavior

LED	Color/Pattern	Description	LED Power Saving Mode ^a
Power	Off	No power or input voltage ≥ 36 VDC or ≤ 7 VDC	
	Solid Green	Power is present.	
	Green with Amber Flash	Power is present and the gateway has a GPS fix.	
	Solid Red	Standby mode	
	Flashing Green	When you press the reset button, flashing green indicates when to release the reset button to reboot the gateway.	
	Flashing Red	When you press the reset button, flashing red indicates when to release the reset button to reset the gateway to the factory default settings.	
	Flashing Amber	When you press the reset button for more than 20 seconds, flashing amber indicates when to release the reset button to enter Recovery mode. (See Recovery Mode on page 46.)	
Signal	Solid Green	Good signal (equivalent to 4–5 bars)	Off
	Solid Amber	Fair signal (equivalent to 2–3 bars)	Off
	Flashing Amber	Poor signal (equivalent to 1 bar) If possible, Sierra Wireless recommends moving the gateway to a location with a better signal.	
	Flashing Red	Inadequate (equivalent to 0 bars) Sierra Wireless recommends moving the gateway to a location with a better signal.	

Note: The quality of the signal strength is measured using the appropriate parameters for the radio technology in use.

Table 3-10: LED Behavior

LED	Color/Pattern	Description	LED Power Saving Mode ^a
Network	Solid Green	Connected to an LTE network	Off
	Solid Amber	Connected to a 3G or 2G network	Off
	Flashing Green	Connecting to the network	
	Flashing Red	No network available	
	Flashing Red / Amber	Network Operator Switching is enabled, but the gateway is unable to locate the required firmware. For more information, refer to the ALEOS Software Configuration User Guide (Admin chapter).	
Activity	Flashing Green	Traffic is being transmitted or received over the WAN interface.	
	Flashing Red	Traffic is being transmitted or received over the serial port. This behavior only appears if the RV50 Series gateway is configured to display it. For more information, refer to the ALEOS Software Configuration Guide (Serial chapter).	
	Flashing Amber	Traffic is being transmitted or received over both the WAN interface and the serial port. This behavior only appears if the RV50 Series gateway is configured to display it. Refer to the ALEOS Software Configuration Guide (Serial chapter).	
ALL	Green LED chase	Radio module reconfiguration/firmware update or Network Operator Switching is in progress.	
	Amber LED chase	ALEOS software update is in progress.	
	Solid Amber	ALEOS software update complete (all LEDs are amber except the Power LED)	
	Red LED chase	The gateway is in Recovery mode.	

a. To configure LED Power Saving Mode, refer to the ALEOS Software Configuration User Guide (Services chapter).

Ethernet LEDs

The Ethernet connector has two LEDs that indicate speed and activity. When looking into the connector:

- Activity—The right LED is solid amber when a link is present and flashing amber when there is activity.
- Connection Speed—The left LED indicates the Ethernet connection speed:
 - Solid Green—1000 Mbps
 - Solid Amber—100 Mbps
 - Off—10 Mbps

Step 6—Startup and Software Configuration

You can configure the ALEOS software on the RV50 Series gateway using:

- [ACEmanager](#) (browser-based application)
- [AirLink Management Service](#) (cloud-based application)
- [AirLink Mobility Manager](#) (AMM)

- [AT Commands](#)

Configuring with ACEmanager

To access ACEmanager:

1. Connect a laptop to the gateway with an Ethernet cable.
2. Launch your web browser and go to **http://192.168.13.31:9191**.

Note: It takes the gateway 2–3 minutes to respond after power up.

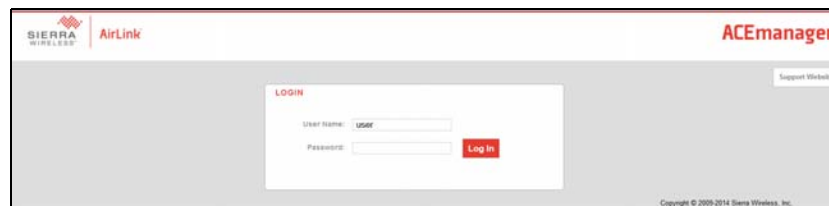

Figure 3-18: ACEmanager login window

3. Enter the default password.
 - For devices that support unique passwords, the default password is printed on the device label.
 - For other devices, the default password is 12345.
4. Click Log In.

Note: For system security, ensure that you change the default password as soon as possible.

5. Refer to the ALEOS Software Configuration User Guide for information on how to use ACEmanager to configure your RV50 Series gateway.

Configuring with AirLink Management Service

AirLink Management Service (ALMS) allows remote management of all your gateways from one user interface.

Some of its features include:

- Centralized, remote monitoring for all your AirLink gateways
- Continuous status monitoring of important health data such as signal strength
- Location monitoring, including world map views
- Complete ALEOS reporting and configuration, including historical views of ALEOS information
- Configure individual gateways or use templates to perform batch configurations of your AirLink gateways
- Single click over-the-air firmware updates to all your gateways
- Compatible with all carriers or mobile network operators

To get started either call your AirLink reseller or visit:

www.sierrawireless.com/ALMS

Configuring with AMM

AirLink Mobility Manager (AMM) is a Network Management solution that provides a consolidated view of the entire vehicle fleet and enables simplified management, control and monitoring of connected AirLink routers. AMM is a licensed, unified software platform deployed in the enterprise data center. It enables:

- Mobile network and asset management
- Over-the-air registration, configuration and software updates
- Consolidated network view of an entire fleet, in-field applications and mobile assets, using a virtual dashboard to monitor, report, manage, and troubleshoot all mobile resources as required.

If you require a network management solution deployed in your data center, contact your Sierra Wireless sales representative for a demonstration of AMM capabilities.

Configuring with AT Commands

For a complete list of AT commands, refer to the ALEOS Software Configuration User Guide.

Transitioning from a Raven Gateway

If you are transitioning from a Raven XT or Raven XE to an AirLink RV50 Series gateway and you want to maintain a similar level of power consumption, Sierra Wireless recommends the settings outlined in [Table 3-11](#). For step by step instructions, refer to the ALEOS Software Configuration User Guide (Power Saving Features).

Table 3-11: Recommended Power Saving Settings—Transitioning from Raven XT or Raven XE

Feature	Setting (transitioning from Raven XT)	Setting (transitioning from Raven XE)	Default/Location in ACEmanager
GPS	Off	Off	Off by default (GPS > Global Settings)
Ethernet Port	Off	On	On by default (LAN > Ethernet > General)
Ethernet Link Setting (data rate)	n/a	Recommend 10 Mbps or 100 Mbps, unless 1000 Mbps is required	Auto 10/100/1000 by default (LAN> Ethernet > Advanced)
USB Port	On	Off, unless a USB connection is required	On by default (LAN > USB > General)
Serial Port	On	Off	On by default (Serial > Port Configuration)

Table 3-11: Recommended Power Saving Settings—Transitioning from Raven XT or Raven XE

Feature	Setting (transitioning from Raven XT)	Setting (transitioning from Raven XE)	Default/Location in ACEmanager
LED Power Saving Mode	Enable	Enable	Disabled by default (Services > Power Management > Power Saving Modes)
Processor Power Saving Mode	Enable	Enable	Disabled by default (Services > Power Management > Power Saving Modes)

Step 7—Mounting the RV50 Series Gateway

Warning: *This gateway is not intended for use close to the human body. Antennas should be at least 8 inches (20 cm) away from the operator.*

Mount the gateway where:

- There is easy access to the cables
- Cables are not bent, constricted, close to high amperages or exposed to extreme temperatures
- The front panel LEDs are easily visible
- There is adequate airflow
- It is away from direct exposure to the elements, such as sun, rain, dust, etc.
- It will not be hit or come into contact with people, cargo, tools, equipment, etc.

Mounting Brackets

The RV50 Series gateway comes with mounting screws. An optional DIN rail mounting bracket (P/N 6000659) is available from Sierra Wireless.

Flat Surface Mount

If you are mounting the RV50 Series gateway on a flat surface, use the mounting screws that come with the gateway.

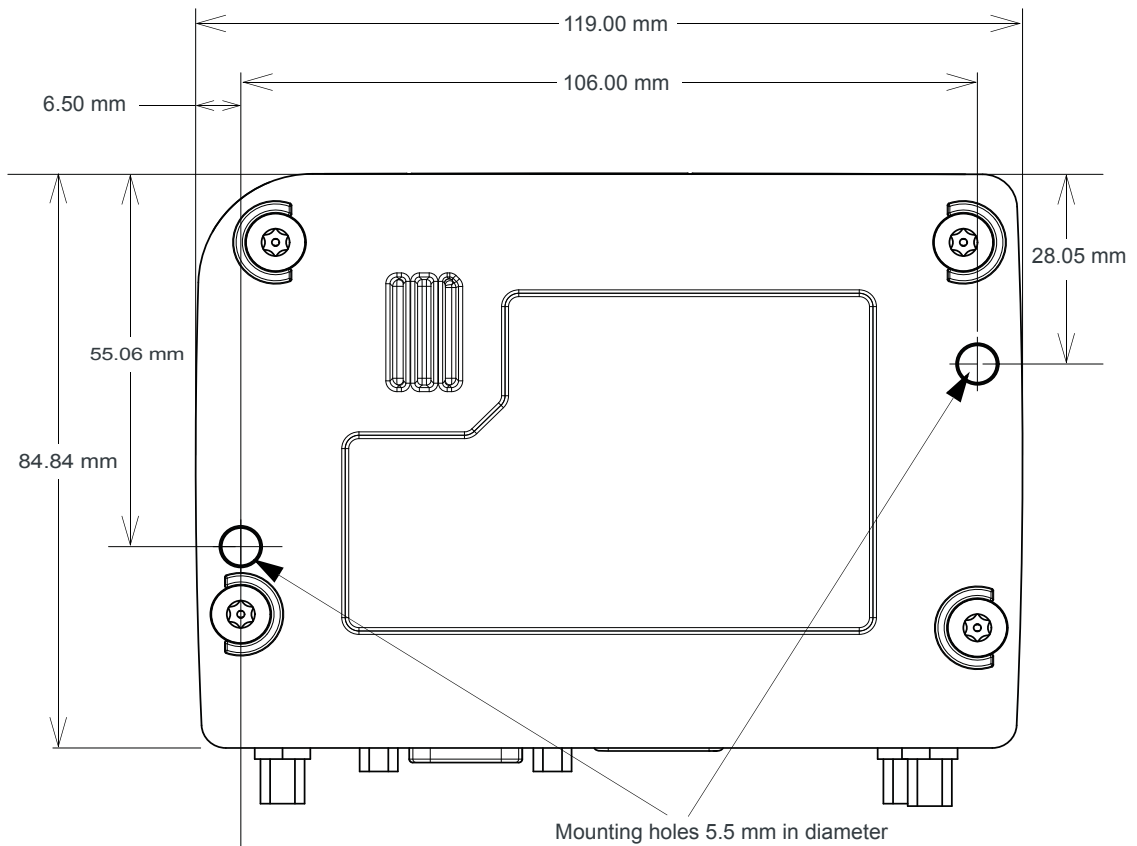

Figure 3-19: RV50 Series Gateway Mounting Bracket for Flat Surfaces

DIN Rail Mount

If you are mounting the RV50 Series gateway on a DIN rail, order DIN rail mounting bracket kit (P/N 6000659) from Sierra Wireless. The kit contains:

- L-shaped DIN Rail Mounting Bracket—Qty 1
- DIN Rail Clip (35 mm EN 50022)—Qty 1
- Screws

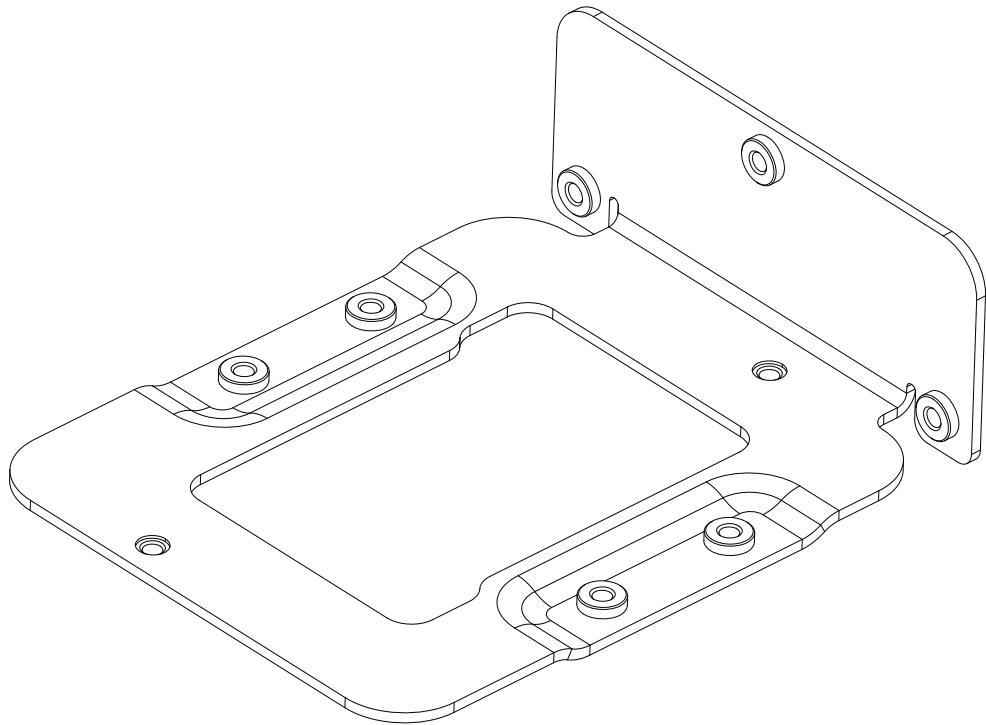

Figure 3-20: DIN Rail Mounting Bracket

To attach the RV50 Series gateway to a horizontally mounted DIN rail, in a variety of orientations:

1. Install the SIM card. (See [Step 1—Insert the SIM Cards](#) on page 21.)
2. Test the network connectivity.
Connect the RV50 Series gateway. Power it up and ensure that you have network connectivity. (See [Step 4—Connect the Power](#) on page 25.)
3. Place the gateway on the DIN rail mounting bracket, lining up the mounting holes on the underside of the gateway with the holes on the DIN rail mounting bracket.
4. Use the screws provided to attach the gateway to the bracket. Torque the screws to a maximum of 1.1 N-m (10 in-lb.).
5. Use the screws provided to attach the DIN rail clip to the bracket.
6. Attach the DIN rail clip to a horizontal DIN rail, with the spring clip at the bottom, taking into account the location information described in [Power Consumption Scenarios](#) on page 13.

Note: The DIN rail mounting bracket and clip in the Sierra Wireless kit should only be used on horizontally-mounted DIN rail.

Reboot the RV50 Series Gateway

To reboot the RV50 Series gateway:

- On the gateway, press the Reset button for 1–5 seconds. (Release the button when the Power LED flashes green.)
- In ACEmanager, click the Reboot button on the toolbar.

Reset the RV50 Series Gateway to Factory Default Settings

To reset the gateway to the factory default settings:

- On the gateway, press the Reset button for more than 5 seconds. (Release the button when the Power LED flashes red.)
Once the LEDs resume their normal operating behavior, the reset is complete.
- In ACEmanager, go to Admin > Advanced and click the Reset to Factory Default button.

Tip: In ACEmanager, you can configure the RV50 Series gateway to preserve mobile network authentication settings such as the network ID, network password, custom APNs, Primary SIM, and Mobile Network Operator firmware when the gateway is reset to the factory default settings. For more details, refer to the ALEOS Software Configuration User Guide (Admin chapter).

Recovery Mode

If the router fails to boot properly, it automatically enters recovery mode, or, if the router is unresponsive to ACEmanager input and AT commands, you can manually put the router into recovery mode.

Recovery mode enables you to update the ALEOS software and return the router to working order. (For details, refer to the ALEOS Software Configuration User Guide—Configuring your router chapter.)

To enter Recovery mode manually:

- On the router, press the Reset button for more than 20 seconds. (Release the button when the Power LED flashes amber.)

To recover the router:

- Update ALEOS using the Recovery mode interface. Once the new ALEOS version is successfully uploaded and installed, the gateway reboots and exits recovery mode. When the process is complete, the ACEmanager login screen appears.

Note: After the recovery, you need to reload the radio module firmware store and templates.

To exit Recovery mode, if it has been inadvertently entered, do one of the following:

- Press the reset button on the gateway to reboot it.

- Click the Reboot button on the Recovery screen.
- Wait 10 minutes. If no action is taken within 10 minutes of the device entering Recovery mode (for example, if the Recovery screen has not been loaded by the web browser), it automatically reboots and exits Recovery mode.

For more information, refer to the ALEOS Software Configuration User Guide (Configuring your router chapter).

4: RV50 Series Specifications

This chapter provides the specifications for the standard RV50 and the RV50X.

Radio Frequency Bands

Use the following table as a guide to the radio frequencies supported by the RV50 and RV50X radio modules.

To determine which radio module your gateway has, refer to the label on the bottom of the gateway, or in ACEmanager, go to Status > About, and check the Radio Module Type field.

	RV50		RV50X	
Radio Module	MC7354	MC7304	MC7455	MC7430
Radio Frequency Bands	Table 4-1	Table 4-2	Table 4-3	Table 4-4
Radio Module Transmit Power	Table 4-5	Table 4-6	Table 4-7	Table 4-8
Carrier Aggregation	—	—	Table 4-9	Table 4-10
GNSS Technology/ GNSS Bands Supported	Table 4-11			

Table 4-1: RV50 MC7354 North America

Radio Technology	SKU				Band	Frequencies
	Generic	Verizon Wireless	AT&T	Sprint		
LTE	✓		✓		Band 2 (1900 MHz)	Tx: 1850–1910 MHz Rx: 1930–1990 MHz
	✓	✓	✓		Band 4 (AWS) (1700/2100 MHz)	Tx: 1710–1755 MHz Rx: 2110–2155 MHz
	✓		✓		Band 5 (850 MHz)	Tx: 824–849 MHz Rx: 869–894 MHz
	✓	✓			Band 13 (700 MHz)	Tx: 777–787 MHz Rx: 746–756 MHz
	✓		✓		Band 17 (700 MHz)	Tx: 704–716 MHz Rx: 734–746 MHz
	✓			✓	Band 25 (1900 MHz Block G)	Tx: 1850–1915 MHz Rx: 1930–1995 MHz

Table 4-1: RV50 MC7354 North America (Continued)

Radio Technology	SKU				Band	Frequencies
	Generic	Verizon Wireless	AT&T	Sprint		
EV-DO	✓	✓		✓	BC0 (Cellular 800 MHz)	Tx: 824–849 MHz Rx: 869–894 MHz
	✓	✓		✓	BC1 (PCS 1900 MHz)	Tx: 1850–1910 MHz Rx: 1930–1990 MHz
	✓			✓	BC10 (Secondary 800 MHz)	Tx: 817–824 MHz Rx: 861–869 MHz
HSPA	✓	✓	✓	✓	Band 1 (2100 MHz)	Tx: 1920–1980 MHz Rx: 2110–2170 MHz
	✓	✓	✓	✓	Band 2 (1900 MHz)	Tx: 1850–1910 MHz Rx: 1930–1990 MHz
	✓				Band 4 (AWS 1700/2100 MHz)	Tx: 1710–1755 MHz Rx: 2110–2155 MHz
	✓	✓	✓	✓	Band 5 (850 MHz)	Tx: 824–849 MHz Rx: 869–894 MHz
	✓	✓	✓	✓	Band 8 (900 MHz)	Tx: 880–915 MHz Rx: 925–960 MHz
EDGE	✓	✓	✓	✓	GSM 850 (850 MHz)	Tx: 824–849 MHz Rx: 869–894 MHz
	✓	✓	✓	✓	GSM 900 (900 MHz)	Tx: 880–915 MHz Rx: 925–960 MHz
	✓	✓	✓	✓	DCS 1800 (1800 MHz)	Tx: 1710–1785 MHz Rx: 1805–1880 MHz
	✓	✓	✓	✓	PCS 1900 (1900 MHz)	Tx: 1850–1910 MHz Rx: 1930–1990 MHz

Table 4-2: RV50 MC7304 International

Radio Technology	SKU		Band	Frequencies
	Generic	Telstra		
LTE	✓	✓	Band 1 (2100 MHz)	Tx: 1920–1980 MHz Rx: 2110–2170 MHz
	✓	✓	Band 3 (1800 MHz)	Tx: 1710–1785 MHz Rx: 1805–1880 MHz
	✓	✓	Band 7 (2600 MHz)	Tx: 2500–2570 MHz Rx: 2620–2690 MHz
	✓	✓	Band 8 (900 MHz)	Tx: 800–915 MHz Rx: 925–960 MHz
	✓	✓	Band 20 (800 MHz)	Tx: 832–862 MHz Rx: 791–821 MHz
HSPA	✓	✓	Band 1 (2100 MHz)	Tx: 1920–1980 MHz Rx: 2110–2170 MHz
	✓	✓	Band 2 (1900 MHz)	Tx: 1850–1910 MHz Rx: 1930–1990 MHz
	✓	✓	Band 5 (850 MHz)	Tx: 824–849 MHz Rx: 869–894 MHz
	✓	✓	Band 6 (800 MHz)	Tx: 830–840 MHz Rx: 875–885 MHz
	✓	✓	Band 8 (900 MHz)	Tx: 880–915 MHz Rx: 925–960 MHz
EDGE	✓	✓	GSM 850 (850 MHz)	Tx: 824–849 MHz Rx: 869–894 MHz
	✓	✓	GSM 900 (900 MHz)	Tx: 880–915 MHz Rx: 925–960 MHz
	✓	✓	DCS 1800 (1800 MHz)	Tx: 1710–1785 MHz Rx: 1805–1880 MHz
	✓	✓	PCS1900 (1900 MHz)	Tx: 1850–1910 MHz Rx: 1930–1990 MHz

Table 4-3: RV50X Radio Module MC7455 North America and EMEA

Radio Technology	SKU				Band	Frequencies
	Generic	Verizon Wireless	AT&T	Sprint		
LTE	✓		✓	✓	Band 1	Tx: 1920–1980 MHz Rx: 2110–2170 MHz
	✓	✓	✓	✓	Band 2	Tx: 1850–1910 MHz Rx: 1930–1990 MHz
	✓		✓	✓	Band 3	Tx: 1710–1785 MHz Rx: 1805–1880 MHz
	✓	✓	✓	✓	Band 4	Tx: 1710–1755 MHz Rx: 2110–2155 MHz
	✓	✓	✓	✓	Band 5	Tx: 824–849 MHz Rx: 869–894 MHz
	✓		✓	✓	Band 7	Tx: 2500–2570 MHz Rx: 2620–2690 MHz
	✓		✓	✓	Band 8	Tx: 880–915 MHz Rx: 925–960 MHz
	✓		✓	✓	Band 12	Tx: 699–716 MHz Rx: 729–746 MHz
	✓	✓	✓	✓	Band 13	Tx: 777–787 MHz Rx: 746–756 MHz
	✓		✓	✓	Band 20	Tx: 832–862 MHz Rx: 791–821 MHz
	✓		✓	✓	Band 25	Tx: 1850–1915 MHz Rx: 1930–1995 MHz
	✓		✓	✓	Band 26	Tx: 814–849 MHz Rx: 859–894 MHz
	✓		✓	✓	Band 29	Tx: n/a Rx: 717–728 MHz
	✓		✓	✓	Band 41	2496–2690 MHz (TDD)

Table 4-3: RV50X Radio Module MC7455 North America and EMEA

Radio Technology	SKU				Band	Frequencies
	Generic	Verizon Wireless	AT&T	Sprint		
HSPA+	✓	✓	✓	✓	Band 1	Tx: 1920–1980 MHz Rx: 2110–2170 MHz
	✓	✓	✓	✓	Band 2	Tx: 1850–1910 MHz Rx: 1930–1990 MHz
	✓	✓	✓	✓	Band 3	Tx: 1710–1785 MHz Rx: 1805–1880 MHz
	✓	✓	✓	✓	Band 4	Tx: 1710–1755 MHz Rx: 2110–2155 MHz
	✓	✓	✓	✓	Band 5	Tx: 824–849 MHz Rx: 869–894 MHz
	✓	✓	✓	✓	Band 8	Tx: 880–915 MHz Rx: 925–960 MHz

Table 4-4: RV50X Radio Module MC7430 Asia Pacific

Radio Technology	SKU			Band	Frequencies
	Generic	Telstra	DoCoMo		
LTE	✓	✓	✓	Band 1	Tx: 1920–1980 MHz Rx: 2110–2170 MHz
	✓	✓	✓	Band 3	Tx: 1710–1785 MHz Rx: 1805–1880 MHz
	✓	✓	✓	Band 5	Tx: 824–849 MHz Rx: 869–894 MHz
	✓	✓	✓	Band 7	Tx: 2500–2570 MHz Rx: 2620–2690 MHz
	✓	✓	✓	Band 8	Tx: 800–915 MHz Rx: 925–960 MHz
	✓	✓	✓	Band 18	Tx: 815–830 MHz Rx: 860–875 MHz
	✓	✓	✓	Band 19	Tx: 830–845 MHz Rx: 875–890 MHz
	✓	✓	✓	Band 21	Tx: 1447.9–1462.9 MHz Rx: 1495.9–1510.9 MHz
	✓	✓		Band 28	Tx: 703–748 MHz Rx: 758–803 MHz
	✓	✓	✓	Band 38	2570–2620 MHz (TDD)
	✓	✓	✓	Band 39	1880–1920 MHz (TDD)
	✓	✓	✓	Band 40	2300–2400 MHz (TDD)
	✓	✓	✓	Band 41	2496–2690 MHz (TDD)

Table 4-4: RV50X Radio Module MC7430 Asia Pacific (Continued)

Radio Technology	SKU			Band	Frequencies
	Generic	Telstra	DoCoMo		
HSPA+	✓	✓	✓	Band 1	Tx: 1920–1980 MHz Rx: 2110–2170 MHz
	✓	✓	✓	Band 5	Tx: 824–849 MHz Rx: 869–894 MHz
	✓	✓	✓	Band 6	Tx: 830–840 MHz Rx: 875–885 MHz
	✓	✓	✓	Band 8	Tx: 880–915 MHz Rx: 925–960 MHz
	✓	✓		Band 9	Tx: 1749.9–1784.9 MHz Rx: 1844.9–1879.9 MHz
	✓	✓	✓	Band 19	Tx: 830–845 MHz Rx: 875–890 MHz
TD-SCDMA				Band 39	1880–1920 MHz

Radio Module Conducted Transmit Power

The following tables provide radio module conducted transmit power specifications. The radio module type is printed on the label on the bottom of the gateway and is available in ACEmanager (Status > About).

Table 4-5: RV50 Radio Module MC7354 Conducted Transmit Power

Band	Conducted Tx Power (dBm)	Notes
LTE		
Band 2 Band 4 Band 5 Band 13 Band 17 Band 25	+23±1	
UMTS		
Band 1 (IMT 2100 12.2 kbps) Band 2 (UMTS 1900 12.2 kbps) Band 4 (AWS 1700/2100 12.2 kbps) Band 5 (UMTS 850 12.2 kbps) Band 8 (UMTS 900 12.2 kbps)	+23±1	Connectorized (Class 3)
GSM / EDGE		

Table 4-5: RV50 Radio Module MC7354 Conducted Transmit Power

Band	Conducted Tx Power (dBm)	Notes
GSM 850 CS GSM 900 CS	+32±1	GMSK mode, connectorized (Class 4)
	+27±1	8 PSK mode, connectorized (Class E2)
DCS 1800 CS PCS 1900 CS	+29±1	GMSK mode, connectorized (Class 4)
	+26±1	8 PSK mode, connectorized (Class E2)
CDMA		
Band Class 0 (Cellular)	+24+0.5/-1	
Band Class 1 (PCS)		
Band Class 10 (Cellular)		

Table 4-6: RV50 Radio Module MC7304 Conducted Transmit Power

Band	Conducted Tx Power (dBm)	Notes
LTE		
Band 1 Band 3 Band 8 Band 20	+23±1	
Band 7	+22±1	
UMTS		
Band 1 (IMT 2100 12.2 kbps) Band 2 (UMTS 1900 12.2 kbps) Band 5 (UMTS 850 12.2 kbps) Band 6 (UMTS 800 12.2 kbps) Band 8 (UMTS 900 12.2 kbps)	+23±1	Connectorized (Class 3)
GSM / EDGE		
GSM 850 CS GSM 900 CS	+32±1	GMSK mode, connectorized (Class 4)
	+27±1	8 PSK mode, connectorized (Class E2)

Table 4-6: RV50 Radio Module MC7304 Conducted Transmit Power

Band	Conducted Tx Power (dBm)	Notes
DCS 1800 CS PCS 1900 CS	+29±1	GMSK mode, connectorized (Class 4)
	+26±1	8 PSK mode, connectorized (Class E2)

Table 4-7: RV50X Radio Module MC7455 Conducted Transmit Power

Band	Conducted Tx Power (dBm)	Notes
LTE		
Bands 1, 2, 3, 4, 5, 8, 12, 13, 20, 25, 26	+23±1	
Bands 7, 30, 41	+22±1	
HSPA+		
Band 1 (IMT 2100 12.2 kbps) Band 2 (UMTS 1900 12.2 kbps) Band 4 (AWS 1700/2100 12.2 kbps) Band 5 (UMTS 850 12.2 kbps) Band 8 (UMTS 900 12.2 kbps)	+23±1	Connectorized (Class 3)

Table 4-8: RV50X Radio Module MC7430 Conducted Transmit Power

Band	Conducted Tx Power (dBm)	Notes
LTE		
Bands 1, 3, 5, 8, 18, 19, 21, 28, 39	+23±1	
Band 7, 38, 40, 41	+22±1	
HSPA+		
Band 1 (IMT 2100 12.2 kbps) Band 5 (UMTS 850 12.2 kbps) Band 6 (UMTS 800 12.2 kbps) Band 8 (UMTS 900 12.2 kbps) Band 9 (UMTS 1700 12.2 kbps) Band 19 (UMTS 850 12.2 kbps)	+23±1	Connectorized (Class 3)
TD-SCDMA		
Band 39	+23±1	

Carrier Aggregation Combinations

LTE-Advanced uses carrier aggregation to increase bandwidth. The following tables show the carrier aggregation combinations.

Table 4-9: RV50X MC7455 Carrier Aggregation Combinations

1 + 8
2 + 2/5/12/13/29
3 + 7/20
4 + 4/5/12/13/29
5 + 2/4
7 + 3/7/20
8 + 1
12 + 2/4
13 + 2/4
20 + 3/7
41 + 41

Table 4-10: RV50X MC7430 Carrier Aggregation Combinations

1 + 8/18/19/21
3 + 5/7/19/28
5 + 3/7
7 + 3/5/7/28
8 + 1
18 + 1
19 + 1/3/21
21 + 1/19
28 + 3/7
38 + 38
39 + 39
40 + 40
41 + 41

GNSS Technology

Table 4-11: GNSS DC Bias Voltage

Signal	Description	Current/Voltage		
		Minimum	Typical	Maximum
GNSS Signal	Active bias on GNSS port	50 mA	75 mA	100 mA
	Maximum voltage output at 75 mA	—	—	3.3 V

SIM Interface

- The RV50 Series gateway has two 6-pin SIM sockets for mini-SIM (2FF) SIM cards, operated at 1.8 V/3.3 V.
- This interface is compliant with the applicable 3GPP standards for USIM.

Reliability Specifications

The RV50 Series gateway has an MTBF (Ground Benign, 25°C) as follows:

- RV50 North America: 878875 hours (100.2 years)
- RV50 International: 933291 hours (106.4 years)
- RV50X North America and EMEA: 1413853 hours (161.4 years)
- RV50X Asia Pacific: 1605817 hours (183.3 years)

MTBF calculations are performed per:

- Telcordia “Reliability Prediction Procedure for Electronic Equipment” document number SR-332, Method I, Issue 3

Mechanical Specifications

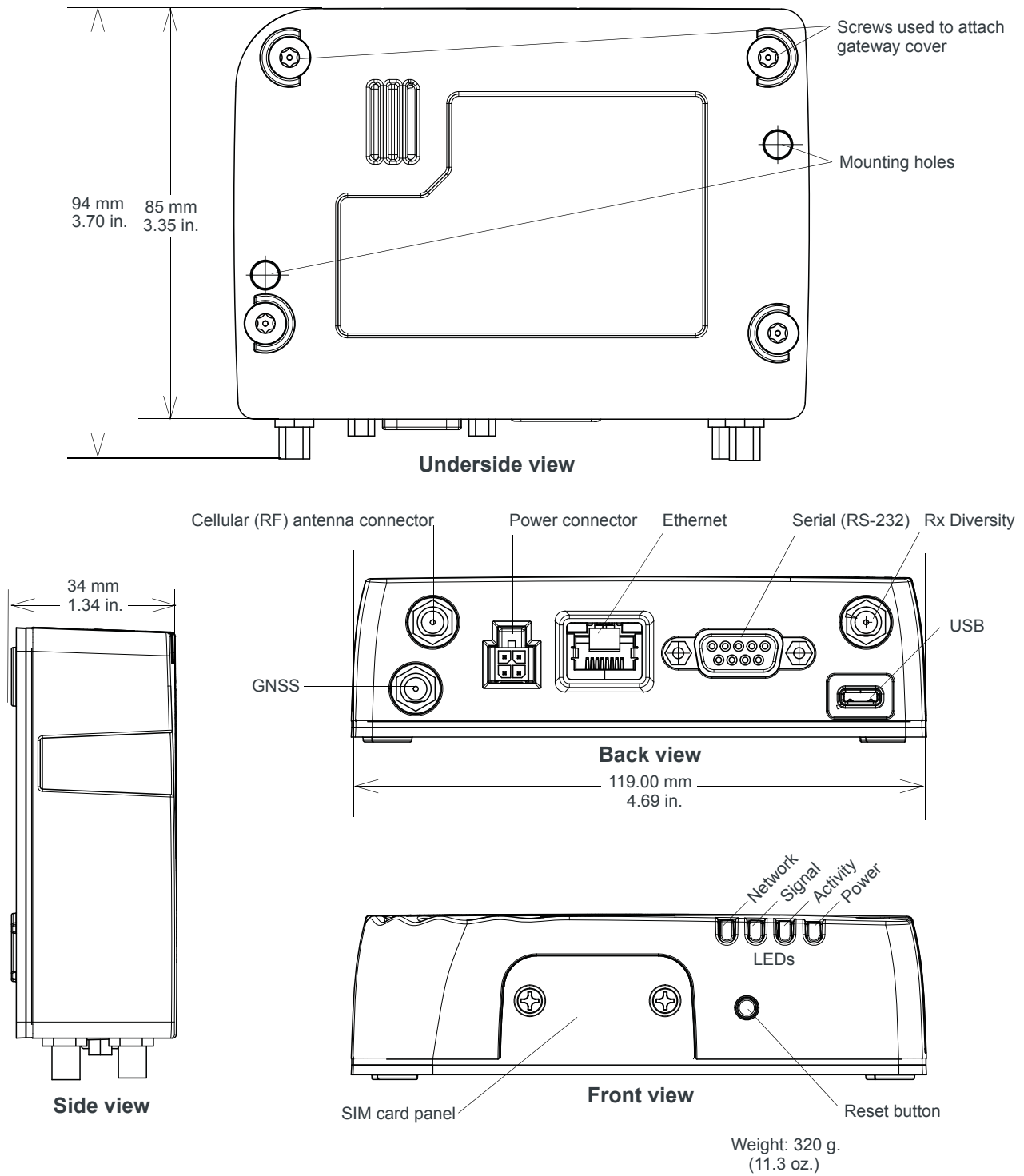

Figure 4-1: RV50 Series Gateway Mechanical Specifications

Power Specifications

Table D-12: Power Supply Specifications

Pin	Name	Specification	Parameter	Minimum	Maximum
1	VCC	Voltage range	VCC	7 V	36 V

Table D-13: Ignition Sense Specifications

Pin	Name	Input Impedance (Typ)	Specification	Parameter	Minimum	Maximum
3	IS (Input only)	160 k Ω	Input low state voltage (maximum)	VIL	—	1.0 V
			Input high state voltage (minimum guaranteed)	VIH	3.3 V	V _{in}

*Note: If you do not connect this pin to the ignition, you **MUST** connect it to the positive terminal of your power supply or battery. The device looks for a qualified voltage on this pin as part of the power up sequence. If it doesn't see a qualified voltage, the device will not turn on. If you are using a Sierra Wireless AC power adapter, the connection is inside the cable.*

>> 5: Regulatory Information

Important Information for North American Users

Note: This equipment has been tested and found to comply with the limits for a Class A digital device, pursuant to part 15 of the FCC Rules. These limits are designed to provide reasonable protection against harmful interference when the equipment is operated in a commercial environment. This equipment generates, uses, and can radiate radio frequency energy and, if not installed and used in accordance with the instruction manual, may cause harmful interference to radio communications. Operation of this equipment in a residential area is likely to cause harmful interference, in which case the user will be required to correct the interference at his own expense.

Warning: *Changes or modifications to this device not expressly approved by Sierra Wireless could void the user's authority to operate this equipment.*

RF Exposure

In accordance with FCC/IC requirements of human exposure to radio frequency fields, the radiating element shall be installed such that a minimum separation distance of 20 cm should be maintained from the antenna and the user's body.

Warning: *This product is only to be installed by qualified personnel.*

To comply with FCC/IC regulations limiting both maximum RF output power and human exposure to RF radiation, the maximum antenna gain must not exceed the specifications listed below for the device used.

Maximum Antenna Gain

The antenna gain must not exceed the limits and configurations shown in the following table:

Device	Frequency Band	Gain
AirLink RV50: N7NMC7355 2417C-MC7355	Cellular Band	4.0 dBi
	PCS Band	3.0 dBi
	Band 2	3.0 dBi
	Band 4	4.0 dBi
	Band 5	4.0 dBi
	Band 13	4.0 dBi
	Band 17	4.0 dBi
	Band 25	3.0 dBi
AirLink 50X: N7NMC7455 2417C-MC7455	Bands 2, 4, 5, 12, 13, 25, 26	6 dBi
	Bands 7, 41	9 dBi

EU

Sierra Wireless hereby declares the AirLink RV50 Series devices are in compliance with the essential requirements and other relevant provisions of Directive 2014/53/EU.

The RV50 Series devices display the CE mark.



Warning: Changes or modifications to this device not expressly approved by Sierra Wireless could void the user's authority to operate this equipment.

Warning: This product is only to be installed by qualified personnel.

Declaration of Conformity

The Declaration of Conformity made under Directive 2014/53/EU is available for viewing at:

RV50: source.sierrawireless.com/resources/airlink/certification_and_type_approval/RV50_ce_declaration_of_conformity/

RV50X: source.sierrawireless.com/resources/airlink/certification_and_type_approval/RV50X_ce_declaration_of_conformity/

WEEE Notice



If you purchased your AirLink RV50 Series device in Europe, please return it to your dealer or supplier at the end of its life. WEEE products may be recognized by their wheeled bin label on the product label.

Notice for Brazilian Users

Warning: *This is a class A product. In a domestic environment this product may cause radio interference in which case the user may be required to take adequate measures.*

>> A: Accessories

DC Power Cable (Black Connector)

Table A-1: DC Power Cable

DC Power Cable	
Part Number	2000522
Product Release	2016

Components:

- ① 1 UL2464 20 AWG × 4 core cable
- ② 4 Molex female crimp terminals /AWG 20-24, 250 V, 4 A Max, phosphor bronze tin-plated (part number 43030-0001)
- ③ 1 Molex male 2×2P Ph: 3.0 mm housing, 250 V, 5 A max, PA65 black UL94V-O (part number 43025-0408)

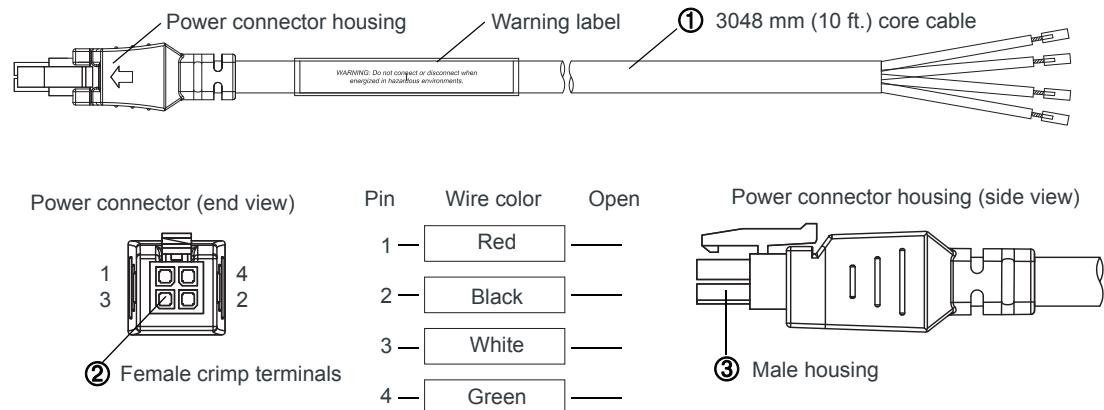

Figure A-1: DC Cable Specifications

AC Power Adapter (Black Connector)

Note: Please note that the AC power adapter is not available for sale in New Zealand (as of June 1, 2018).

AC Power Adapter	
Part Number	2000579
Product Release Date	2016

AC Power Adapter Input

Table A-2: Input Specifications

	Minimum	Typical	Maximum
Input			
Input Voltage	90 VAC	100–240 VAC	264 VAC
Input Frequency	47 Hz	50/60 Hz	63 Hz
<p><i>Note: Input voltage range is 90 VAC to 264 VAC. Maximum input current is 500 mA at 100–240 VAC. Inrush current will not exceed 75 A at 100–240 VAC input and maximum load from a cold start at 25°C.</i></p>			

AC Power Adapter Output

Table A-3: AC Power Adapter Output Specifications

	Minimum	Typical	Maximum	Test conditions
Output Voltage	11.4 VDC	12.0 VDC	12.6 VDC	0 ~ 1.5 A loading

AC Power Adapter Environmental Specifications

Table A-4: AC Power Adapter Environmental Specifications

Operating	
Operating Temperature	0°C ~ 40°C (operates normally)
Relative Humidity	10% ~ 90%
Altitude	Sea level to 2,000 meters
Vibration	1.0 mm, 10–55 Hz, 15 minutes per cycle for each axis (X, Y, Z)
Non-operating	
Storage Temperature	-30°C ~ 70°C
Relative Humidity	10% ~ 90%
Vibration and Shock	MIL-STD-810D, method 514

AC Power Adapter Reliability and Quality Control

AC Power Adapter MTBF

When the power supply is operating within the limits of this specification, the MTBF is at least 200,000 hours at 25°C (MIL-HDBK-217F).

Note: For gateway MTBF, see [Reliability Specifications](#) on page 59.

AC Power Adapter Safety Standards

The power supply is certified with the following international regulatory standards:

Table 1-5: AC Power Adapter Safety Standards

Regulatory Agency	Country or Region	Certified	Standard
UL	USA	Approved	UL60950-1
GS	Europe	Approved	EN60950-1
CE	Europe	Approved	EN60950-1
SAA	Australia	Approved	AS/NZS 60950
CCC	China	Approved	GB4943
CUL	Canada	Approved	CSA C22.2 NO.60950-1

AC Power Adapter EMC Standards

The power supply meets the radiated and conducted emission requirements for EN55022, FCC Part 15, Class B, GB9254.

AC Power Adapter Hazardous Substances

- EU Directive 2011/65/EU “RoHS”
- EU Directive 2012/19/EU “WEEE”
- REACH

AC Power Adapter Energy Efficiency

The AC adapter complies with International Efficiency Levels, as shown in [Table A-6](#).

Table A-6: AC Adapter Energy Efficiency

Supplied Input	No-load power consumption	Average active mode efficiency	International Efficiency Level
115 VAC, 60 Hz	Less than 0.1 W	Greater than 85%	VI
230 VAC, 50 Hz	Less than 0.3 W	Greater than 80.4%	V

Certified Antennas for Japan

The following antennas have been certified for RV50X in Japan.

Manufacturer	Model
Panorama	LP[G]AM-BC3G-26 WMM-7-27-5SP
Taoglas	GSA.8826 GA.130 MA412 TLS.01

>> | B: Acronyms

Acronym or term	Definition
3GPP	<p>3rd Generation Partnership Project</p> <p>3GPP unites 6 telecommunications standard development organizations (ARIB, ATIS, CCSA, ETSI, TTA, TTC), and provides their members with a stable environment to produce Reports and Specifications that define 3GPP technologies.</p>
API	<p>Application Programming Interface</p> <p>A protocol intended to be used as an interface by software components to communicate with each other.</p>
AT	<p>A set of device commands, preceded by “AT” originally developed by Hayes, Inc. for their devices.</p> <p>The structure (but not the specific commands, that vary greatly from manufacturer to manufacturer) is a de facto device industry standard.</p>
CE, CE label	<p>The CE label is a mandatory conformity marking for products placed on the market in the European Economic Area (EEA).</p> <p>With the CE marking on a product, the manufacturer declares that the product conforms with the essential requirements of the applicable EC directives.</p>
DCE	<p>Data Communications Equipment</p> <p>A device that sits between the data terminal equipment (DTE) and a data transmission circuit. Usually the DCE is a modem.</p>
Diversity	<p>Antenna diversity, also called space diversity, is a scheme that uses two or more antennas to improve the quality and reliability of a wireless link.</p> <p>Often, especially in urban and indoor environments, there is no clear line-of-sight (LOS) between transmitter and receiver. Instead the signal is reflected along multiple paths before finally being received. Each bounce can introduce phase shifts, time delays, attenuations, and distortions that can destructively interfere with one another at the aperture of the receiving antenna.</p>
EDGE	<p>Enhanced Data rates for GSM Evolution</p> <p>A digital mobile phone technology that allows improved data transmission rates as a backward-compatible extension of GSM. EDGE is considered a pre-3G radio technology and is part of ITU's 3G definition.</p> <p>Also known as Enhanced GPRS (EGPRS), or IMT Single Carrier (IMT-SC), or Enhanced Data rates for Global Evolution.</p>

Acronym or term	Definition
EIA	<p>Electronics Industry Association</p> <p>EIA was a standards and trade organization composed as an alliance of trade associations for electronics manufacturers in the United States.</p> <p>They developed standards to ensure the equipment of different manufacturers was compatible and interchangeable. The EIA ceased operations on February 11, 2011, but the former sectors continue to serve the constituencies of EIA.</p>
EMC	<p>Electro Magnetic Compatibility</p> <p>The branch of electrical science that studies the unintentional generation, propagation and reception of electromagnetic energy with reference to the unwanted effects (Electromagnetic interference, or EMI) that such energy may induce.</p>
EMI	<p>Electro Magnetic Interference</p> <p>The disturbance that affects an electrical circuit due to either electromagnetic induction or electromagnetic radiation emitted from an external source.</p>
ERP	<p>Effective Radiated Power</p> <p>A standardized theoretical measurement of radio frequency (RF) energy. It is determined by subtracting system losses and adding system gains.</p>
Ethernet	<p>Computer networking technologies for local area networks (LANs).</p>
EU	<p>The European Union Organization of European countries.</p>
EV-DO	<p>Enhanced Voice-Data Optimized or Enhanced Voice-Data Only (Ev-DO, EV, EVDO, etc.).</p> <p>A telecommunications standard for the wireless transmission of data through radio signals, typically for broadband Internet access. It uses multiplexing techniques including code division multiple access (CDMA) as well as time division multiplexing (TDM) to maximize both individual users' throughput and the overall system throughput.</p>
FCC	<p>Federal Communications Commission</p> <p>The U.S. federal agency responsible for interstate and foreign communications. The FCC regulates commercial and private radio spectrum management, sets rates for communications services, determines standards for equipment, and controls broadcast licensing.</p>
GNSS	<p>Global Navigation Satellite System</p> <p>As of April 2013, only the United States NAVSTAR Global Positioning System (GPS) and the Russian GLONASS are global operational GNSSs. China, the European Union, India, Japan, and others are developing navigation system that are being added as they become operational.</p>

Acronym or term	Definition
GPRS	<p>General Packet Radio Service</p> <p>A packet-oriented mobile data service on 2G and 3G cellular communication systems.</p> <p>GPRS was originally standardized by European Telecommunications Standards Institute (ETSI) in response to the earlier CDPD and i-mode packet-switched cellular technologies. It is now maintained by the 3rd Generation Partnership Project (3GPP).</p>
GPS	<p>Global Positioning System</p> <p>A system that uses a series of 24+ satellites to provide navigational data.</p>
GSM	<p>Global System for Mobile Communications (originally Groupe Spécial Mobile)</p> <p>GSM is a standard developed by the European Telecommunications Standards Institute (ETSI) to describe protocols for second generation (2G) digital cellular networks used by mobile phones.</p>
HSPA	<p>High Speed Packet Access</p> <p>An amalgamation of two mobile telephony protocols: High Speed Downlink Packet Access (HSDPA) and High Speed Uplink Packet Access (HSUPA).</p> <p>This extends and improves the performance of existing 3rd generation mobile telecommunication networks utilizing the WCDMA protocols.</p>
HSPA+	<p>Also called evolved HSPA</p> <p>This allows bit-rates to reach as high as 168 Mbit/s in the downlink and 22 Mbit/s in the uplink. An improved 3GPP standard.</p>
IC	<p>Industry Canada</p> <p>The government department responsible for overseeing and regulating wireless and communication technologies in Canada.</p>
IEC	<p>International Electrotechnical Commission</p> <p>A non-governmental international standards organization that prepares and publishes International Standards for all electrical, electronic and related technologies – collectively known as “electro technology.”</p>
ITU	<p>International Telecommunication Union</p> <p>A specialized agency of the United Nations responsible for issues that concern information and communication technologies.</p> <p>The ITU coordinates the shared global use of the radio spectrum, promotes international cooperation in assigning satellite orbits, and assists in the development and coordination of worldwide technical standards.</p>

Acronym or term	Definition
LED	Light Emitting Diode A semiconductor diode that emits visible or infrared light.
LTE	Long Term Evolution High performance air interface for cellular mobile communication systems.
PPP	Point to Point Protocol An alternative communications protocol used between computers, or between computers and routers on the Internet.
RF	Radio Frequency
RoHS	Restriction of use of Hazardous substances mandated by EU Directive 2002/95.
RS-232	A series of standards for serial binary single-ended data and control signals connecting between a DTE (Data Terminal Equipment) and a DCE (Data Circuit-terminating Equipment). It is commonly used in computer serial ports.
Rx	Receive
SIM, SIM card	Subscriber identity module or subscriber identification module. An integrated circuit that securely stores the international mobile subscriber identity (IMSI) and the related key used to identify and authenticate subscribers on mobile telephony devices (such as mobile phones and computers).
SKU	Stock Keeping Unit Identifies an inventory item: a unique code, consisting of numbers or letters and numbers, assigned to a product by a retailer for purposes of identification and inventory control.
SMS	Short Message Service A feature that allows users of a wireless device on a wireless network to receive or transmit short electronic alphanumeric messages (up to 160 characters, depending on the service provider).
TIA/EIA	Telecommunications Industry Association / Electronics Industry Association A standards setting trade organization, whose members provide communications and information technology products, systems, distribution services and professional services in the United States and around the world.
Tx	Transmit

Acronym or term	Definition
UMTS	Universal Mobile Telecommunications System A third generation mobile cellular system for networks based on the GSM standard. Developed and maintained by the 3GPP (3rd Generation Partnership Project), UMTS is a component of the International Telecommunications Union IMT-2000 standard set and compares with the CDMA2000 standard set for networks based on the competing cdmaOne technology.
USB	Universal Serial Bus An industry standard defining the cables, connectors and communications protocols used in a bus for connection, communication and power supply between computers and electronic devices.

A

Accessories, [14](#)
ACEmanager, [11](#), [41](#)
Acronyms, [69](#)
AirLink Management Service, [11](#), [41](#)
ALEOS software, [40](#)
Analog input, [36](#)
Antenna
 Connecting, [22](#)
 Maximum gain, [63](#)
 Recommended separation, [23](#)
 Safe mounting, [43](#)
Applications, custom, [17](#)
AT commands, [11](#), [42](#)
Authentication, [18](#)

C

Cable strain relief, [25](#)
Cables, connecting, [23](#)
Communication
 AT commands, using, [42](#)
 Command line prompt, using, [38](#)
Configuring the gateway, [11](#)
 AirLink Management Service, [41](#)
 AT commands, [42](#)
Control interface, [59](#)
Current sink, [37](#)

D

DC cable wires, [27](#)
DC voltage transients, [26](#)
Description, product, [8](#)
Digital I/O specifications, [61](#)
Digital output, [38](#)
Dual SIM, [13](#)

E

Ethernet
 LEDs, [40](#)
 Specification, [24](#)
Ethernet, virtual Ethernet port, [24](#)
Events Reporting, [18](#)

F

Features, [8](#)
Fusing, [26](#)

G

Glossary, [69](#)
GNSS, [17](#)
GPS. *See* GNSS
Grounding the chassis, [27](#)

H

Host Interfaces, [16](#)

I

I / O Configuration, [31](#)
Input
 Analog, [36](#)
 Dry contact switch, [35](#)
 Ignition switch, [34](#)
Installation
 Connect data cables, [23](#)
 Connect power cable, [25](#)
 Connecting antennas, [22](#)
 Fixed (with I/O), [31](#)
 Fixed (without I/O), [30](#)
 Insert SIM cards, [21](#)
 overview, [20](#)
 Tools and materials required, [20](#)
 Vehicle, [29](#)
Interface control, [59](#)
IP address, obtaining with command line prompt, [38](#)

L

LED
 Description of LED, [38](#)
 Power Saving Mode, [39](#)

M

Mounting
 Brackets, [43](#)
 DIN rail, [44](#)
 kits, [44](#)
 On DIN rail, [44](#)
MTBF, [59](#)

N

Network Operator Switching, [14](#)

O

Open drain, [38](#)
Operating voltage, [16](#)
Output, digital, [38](#)

P

Pinging the gateway with command line prompt, [38](#)
Ports, [8](#)
Power
 Connecting, [25](#)
 Connector, [25](#)
 input specifications, [61](#)
 Modes, [11](#)
 power supply specifications, [61](#)
Power consumption, sample scenarios, [13](#)

Power saving features, [11](#)
Protocols, [17](#)
Pull-up resistor, [35](#)
Pulse counter, [32](#)

R

Raven XE, [11](#), [42](#)
Raven XT, [11](#), [42](#)
Rebooting, [46](#)
Regulatory information, [62](#)
Regulatory specifications, [68](#)
Reliability, [59](#)
Reset to factory default settings, [46](#)
RF specifications, [22](#)

S

Screw Torque, [16](#)
Security, [17](#)
Serial connector pin-out, [25](#)
Serial port, [24](#)
 Virtual serial port, [24](#)
SIM cards, insert, [21](#)
SIM, dual, [13](#)
Specifications, [15](#), [48](#)
 Environmental, [15](#)
 GNSS, [17](#)
 Input / Output, [16](#)
 Regulatory, [68](#)
 RF, [22](#)
Standards, regulatory, [68](#)

T

Tools required for install, [20](#)

U

USB, [24](#)

V

Vehicle installation
 Alternate, [29](#)
 Recommended, [29](#)
Virtual port, Ethernet or serial, [24](#)
Voltage, input and ripple range, [61](#)
VPN, [17](#)

W

Warranty, [14](#)
Wiring diagrams, [29](#)