



AirLink GX450

Hardware User Guide



SIERRA
WIRELESS®

4114008
Rev 11

Important Notice

Due to the nature of wireless communications, transmission and reception of data can never be guaranteed. Data may be delayed, corrupted (i.e., have errors) or be totally lost. Although significant delays or losses of data are rare when wireless devices such as the Sierra Wireless product are used in a normal manner with a well-constructed network, the Sierra Wireless product should not be used in situations where failure to transmit or receive data could result in damage of any kind to the user or any other party, including but not limited to personal injury, death, or loss of property. Sierra Wireless accepts no responsibility for damages of any kind resulting from delays or errors in data transmitted or received using the Sierra Wireless product, or for failure of the Sierra Wireless product to transmit or receive such data.

Safety and Hazards

Do not operate the Sierra Wireless product in areas where blasting is in progress, near medical equipment, near life support equipment, or any equipment which may be susceptible to any form of radio interference. In such areas, the Sierra Wireless product **MUST BE POWERED OFF**. The Sierra Wireless product can transmit signals that could interfere with this equipment.

The driver or operator of any vehicle should not operate the Sierra Wireless product while in control of a vehicle. Doing so will detract from the driver or operator's control and operation of that vehicle. In some states and provinces, operating such communications devices while in control of a vehicle is an offence.

The GX450 is classified to ANSI/ISA 12.12.01-2013 and CSA C22.2 No 213-M(1987)(R2013) and are suitable for use in Class 1, Division 2, Groups A, B, C and D classified Hazardous Locations.

The following warnings and instructions apply to all GX platforms:

Warning: *EXPLOSION HAZARD—SUBSTITUTION OF COMPONENTS MAY IMPAIR SUITABILITY FOR CLASS I, DIVISION 2.*

Avertissement: *RISQUE D'EXPLOSION-LA SUBSTITUTION DE COMPOSANTS PEUT RENDRE CE MATERIEL INACCEPTABLE POUR LES EMPLACEMENTS DE CLASSE I, DIVISION 2.*

Warning: *EXPLOSION HAZARD—DO NOT DISCONNECT WHILE CIRCUIT IS LIVE UNLESS THE AREA IS KNOWN TO BE NON-HAZARDOUS.*

Avertissement: *RISQUE D'EXPLOSION-NE PAS DEBRANCHER TANT QUE LE CIRCUIT EST SOURS TENSION, A MOINES QU'IL NE S'AGISSE D'UN EMPLACEMENT NON DANGEREUX.*

Warning: *DO NOT USE THE USB CONNECTOR IN A HAZARDOUS AREA.*

Avertissement: *NE PAS UTILISER DE CONNECTEUR USB DANS LES ENVIRONNEMENTS DANGEREUX.*

Warning: *DO NOT USE THE RESET BUTTON IN A HAZARDOUS AREA.*

Avertissement: *NE PAS UTILISER LE BOUTON DE RESET DANS UN ENVIRONNEMENT DANGEREUX.*

Limitation of Liability

The information in this manual is subject to change without notice and does not represent a commitment on the part of Sierra Wireless. SIERRA WIRELESS AND ITS AFFILIATES SPECIFICALLY DISCLAIM LIABILITY FOR ANY AND ALL DIRECT, INDIRECT, SPECIAL, GENERAL, INCIDENTAL, CONSEQUENTIAL, PUNITIVE OR EXEMPLARY DAMAGES INCLUDING, BUT NOT LIMITED TO, LOSS OF PROFITS OR REVENUE OR ANTICIPATED PROFITS OR REVENUE ARISING OUT OF THE USE OR INABILITY TO USE ANY SIERRA WIRELESS PRODUCT, EVEN IF SIERRA WIRELESS AND/OR ITS AFFILIATES HAS BEEN ADVISED OF THE POSSIBILITY OF SUCH DAMAGES OR THEY ARE FORESEEABLE OR FOR CLAIMS BY ANY THIRD PARTY.

Notwithstanding the foregoing, in no event shall Sierra Wireless and/or its affiliates aggregate liability arising under or in connection with the Sierra Wireless product, regardless of the number of events, occurrences, or claims giving rise to liability, be in excess of the price paid by the purchaser for the Sierra Wireless product.

Patents

This product may contain technology developed by or for Sierra Wireless Inc. This product includes technology licensed from QUALCOMM®. This product is manufactured or sold by Sierra Wireless Inc. or its affiliates under one or more patents licensed from MMP Portfolio Licensing.

Copyright

© 2019 Sierra Wireless. All rights reserved.

Trademarks

Sierra Wireless®, AirPrime®, AirLink®, ALEOS® and the Sierra Wireless logo are registered trademarks of Sierra Wireless.

Windows® and Windows Vista® are registered trademarks of Microsoft Corporation.

Macintosh® and Mac OS X® are registered trademarks of Apple Inc., registered in the U.S. and other countries.

QUALCOMM® is a registered trademark of QUALCOMM Incorporated. Used under license.

Other trademarks are the property of their respective owners.

Contact Information

Sales information and technical support, including warranty and returns	Web: sierrawireless.com/company/contact-us/ Global toll-free number: 1-877-687-7795 6:00 am to 5:00 pm PST
Corporate and product information	Web: sierrawireless.com

>> Contents

Introduction to the AirLink GX450	7
Introduction	7
Gateway Description	8
Front Panel	8
Rear Panel	8
X-Cards	10
ALEOS Software	10
ACEmanager	11
AirLink Management Service	11
Accessories	11
Ordering Information	11
Warranty	12
Installation and Startup	13
Tools and Materials Required	13
Installing the SIM Card	14
Installing the SIM Card—No X-Card present	15
Installing the SIM Card—Wi-Fi X-Card present	16
Installing the SIM Card—I/O X-Card present	19
Installing the SIM Card—Dual Ethernet X-Card present	22
Mounting the GX450	25
Vehicle Mounting	26
Antenna Installation	27
Antenna Separation Recommendations	27
Antenna Recommendations	28
Mounting the GPS Antenna	29
Connecting the GX450 Gateway	29
LED Operation	30
Connecting a DC Power Cable	32
Fusing	33
Power Supply Conditioning	33
Power Connector on the GX450 Gateway	33

Serial Port	36
X-Cards	37
Wi-Fi X-Card	38
I/O X-Card	38
Dual Ethernet X-Card	42
Configuring AirLink GX450 Gateways	44
Connection Ports	44
Configuring with ACEmanager	44
Configuring with AirLink Management Service	46
Configuring with AMM	47
Configuring with AT Commands	47
Reset to Factory Default Settings	47
Recovery Mode	47
AirLink GX450 Specifications	49
RF Specifications	49
Radio Frequency Bands	49
Radio Module Conducted Transmit Power	51
Host Interfaces	53
Regulatory Information	60
Federal Communications Commission Notice (FCC United States)	60
Notice for Canadian Users	60
Important Information for North American Users on Radiation Exposure	61
EU	62
Notice for Brazilian Users	63
Accessories	64
DC Power Cable (Black Connector)	64

AC Power Adapter (Black Connector)	65
AC Power Adapter Input	65
AC Power Adapter Output	65
AC Power Adapter Environmental Specifications	66
AC Power Adapter Reliability and Quality Control	66
AC Power Adapter Safety Standards	66
AC Power Adapter EMC Standards	66
Hazardous Substances	67
Energy Efficiency	67
Index	68

>> 1: Introduction to the AirLink GX450

This chapter describes the Sierra Wireless AirLink® GX450 gateway, including a description of ALEOS® embedded software and the AirLink Management Service (ALMS) gateway management platform.

Introduction

The AirLink GX450 gateway is a compact, intelligent and fully-featured cellular (4G LTE) gateway that provides real-time wireless capabilities for fixed and mobile applications such as:

- Public safety vehicle deployments
- Public transit systems
- Energy and utilities
- Remote asset monitoring
- Backup broadband connectivity

The AirLink GX450 gateway has multiple communication ports including serial, Ethernet, and USB ports. The power connector has one digital I/O pin for remote monitoring and control and one ignition sense pin to turn the gateway on and off.

The AirLink GX450 gateway has several expansion options to add more capability. The following options are available:

- Wi-Fi (802.11 b/g/n)
- Input/Output (I/O) 15-pin connector which adds:
 - One additional RS-232 port
 - Four additional digital I/O pins
 - Four analog voltage sensing pins

The AirLink GX450 gateway, when coupled with the rich embedded intelligence provided by the embedded ALEOS software, is the perfect choice for a broad set of machine-to-machine solutions.

Gateway Description

Front Panel

The front panel has the following indicators and controls:



Figure 1-1: GX450 Front Panel

- **LEDs** – These show the gateway’s operating status. The LEDs are described in detail in [LED Operation](#) on page 30.
- **Reset Button** – Momentarily pressing and releasing this button reboots the GX450 gateway.

Note: Holding the Reset button down for 7–10 seconds resets the GX450 gateway to its factory default settings.

Rear Panel

The rear panel has the following connectors and controls:

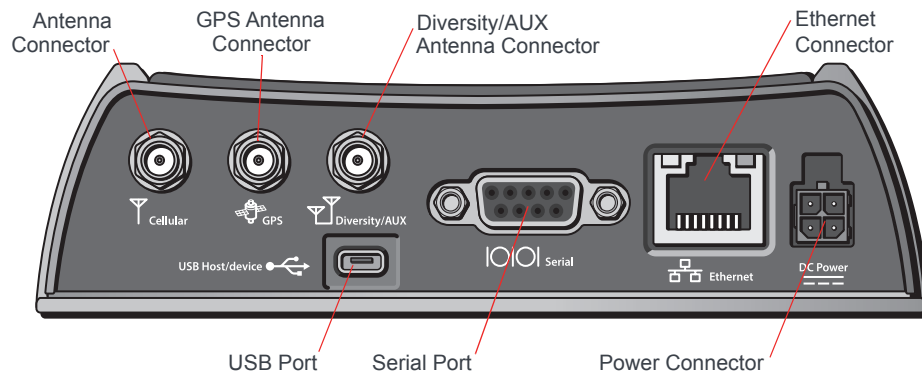

Figure 1-2: GX450 Rear Panel

- **Antenna Connector** – This is the radio’s receive and transmit port (SMA connector).

Note: For more information on antenna connection and use, see [Antenna Installation](#) on page 27.

- **GPS Antenna Connector** – This connects an optional GPS antenna to the gateway. (SMA connector)

Note: The GPS antenna connector has a bias output and Sierra Wireless recommends that you use an active antenna for better sensitivity.

- **Diversity/AUX Antenna Connector** – This connects an auxiliary antenna to the gateway for backup reception capability. (SMA connector)

Note: For 3G networks, the second antenna operates as a diversity antenna, providing a second receive path. For 4G networks, the second antenna operates as a MIMO antenna, providing a second receive path and a second transmit path.

- **Ethernet Connector** – This RJ-45 connector connects a standard Ethernet cable to the gateway. This is used to connect a Windows PC to the gateway for configuration and diagnostic purposes or attaching Ethernet equipment to the gateway.
- **Power Connector** – This connects power to the gateway and provides additional inputs and outputs for the control and monitoring of external devices as well as triggering the low power mode. For more information on its operation and use, see [Connecting a DC Power Cable](#) on page 32.

There are two types of optional power cables available from Sierra Wireless:

- An AC adapter (usually used for indoor, fixed applications where the gateway runs off line power)
- DC cables (usually used in vehicles or other installations where the gateway runs off battery power)

The gateway automatically starts when it senses qualified power on the power connector.

- **Serial Port** – This 9-pin connector provides standard RS-232 communication with a standard straight-through serial cable. It is used to communicate with industrial machines like motors, computers or controllers or for connection to a computer to configure the gateway with AT commands. It also supports features like TCP PAD and UDP PAD. For more information, see [Serial Port](#) on page 36.
- **USB Port** – This Micro AB connector accepts Micro A and Micro B plugs. You can use a connected Windows PC to monitor and configure the gateway.

When connected to a PC, the USB port becomes either a:

- Virtual Ethernet port (default)
- Virtual serial port

For information on configuring the USB port, refer to the ALEOS Software Configuration User Guide. The ALEOS Software Configuration User Guide and Windows drivers for this port are available at

source.sierrawireless.com/resources/airlink/software_downloads/airlink_usb_driver/

When using the USB port:

- Use a USB 2.0 cable
- Connect directly to your computer for best throughput

X-Cards

The AirLink GX450 gateway has several optional, factory-installed, expansion cards (X-Cards) available to add more functions to the basic gateway. They are configurable with the ALEOS ACEmanager software. (See the ALEOS Software Configuration User Guide for more information.)

The options are:

- **Wi-Fi**—Adds Wi-Fi capability to the gateway using the 802.11b/g/n standard
- **I/O**—Has a 15-pin connector which adds to the gateway:
 - One 4-wire RS-232 port
 - Four analog inputs
 - Four high-voltage/high-power digital I/Os with analog readout
- **Dual Ethernet**—Adds two 10/100 baseT Ethernet ports

For a more complete description of each option, see [X-Cards](#) on page 37.

ALEOS Software

Note: For detailed information on all of the features in ALEOS, refer to the ALEOS Software Configuration User Guide, available from source.sierrawireless.com.

ALEOS, the embedded core technology of the AirLink product line, provides:

- Simplified installation, operation and maintenance of any wireless solution
- An always-on, always-aware, intelligent two-way connection for mission-critical applications

ALEOS enables:

- Reverse Telnet
- Reliable Static Routing
- SNMP
- Persistent Network Connectivity
- Over-The-Air (OTA) Upgrades
- Wireless Optimized TCP/IP
- Real-Time Notification
- Real-Time GPS Reporting
- GPS Store and Forward
- Packet Level Diagnostics
- Gateway Management & Control

Sierra Wireless has two tools for monitoring and configuring AirLink GX450 gateways:

- **ACEmanager**—A web-based configuration tool for configuring a single AirLink gateway
- **AirLink Management Service (ALMS)**—A cloud-based gateway management service for monitoring and configuring fleets of AirLink gateways

GX450 gateways also accept AT Commands.

ACEmanager

ACEmanager is a web-based application used to configure and monitor GX450 gateways. ACEmanager:

- Simplifies deployment
- Provides extensive monitoring, control and management capabilities
- Enables you to configure your gateway to meet your needs
- Monitors and controls your AirLink gateway remotely and in real-time
- Is accessed through a web browser connected to the gateway

See [Configuring with ACEmanager](#) on page 44 to learn how to access ACEmanager.

AirLink Management Service

AirLink Management Service (ALMS) is a cloud-based application, accessible from your web browser. It provides remote monitoring and configuration for multiple AirLink ALEOS gateways from a single computer.

ALMS features include:

- Gateway management as a service
- Advanced monitoring dashboards and alert notifications ensuring you always know the status of your GX450 gateways
- Detailed configuration of all ALEOS parameters, including templates providing batch updates of pre-set configurations across multiple gateways
- Over-the-air (OTA) firmware upgrades for all of your AirLink gateways with a single operation

To connect with ALMS, see [Configuring with AirLink Management Service](#) on page 46.

For more information on ALMS, call your Sierra Wireless Partner or visit: www.sierrawireless.com/ALMS.

Accessories

Included with AirLink GX450

- DC power cable
- Mounting screws
- Quick Start Guide

Order separately

- Ethernet cable
- DB-9 serial cable (6 foot and 25 foot lengths)
- USB cable
- Null modem cable
- LTE antenna

Ordering Information

For more information or to place an order, contact: airlinksales@sierrawireless.com.

Warranty

The GX450 has a 3 year standard warranty, with an optional 2 year warranty extension.

2: Installation and Startup

This chapter shows you how to connect, install and start the Sierra Wireless AirLink GX450 gateway. It also describes the front panel LEDs. Also described are the optional X-Cards available from Sierra Wireless that add more functions to the basic gateway.

Tools and Materials Required

- If needed, a SIM card for your gateway as provided by your mobile network operator
If you are installing a SIM card, see [Installing the SIM Card](#) on page 14 for a list of required tools.
- Laptop computer with Ethernet cable
- SMA cellular antenna
- If used, a GPS antenna
- If used, a second SMA cellular antenna
- If used, a straight-through 9-pin connection cable for the RS-232 port
- Power cable, either the DC cable or AC cable ordered from Sierra Wireless or your own custom-made cable

Note: Custom-made cables must incorporate strain relief and use the correct type of power connector to prevent intermittent connection to the gateway.

Note: The gateway has a hardened case for use in industrial and extreme environments. If you are installing it in these types of environments, use cables designed and specified for use in these types of environments to avoid cable failure.

Installing the SIM Card

The GX450 gateway requires a SIM card. If the SIM card has not already been installed by your Mobile Network Operator, install the SIM card before installing or connecting any external equipment or power to the AirLink gateway.

To install a SIM card, you need:

- SIM card for your account (provided by your Mobile Network Operator)
- 2 mm Allen (hex) wrench or a Phillips #1 screwdriver, depending on the screw type used on the black decorative cover
- If your GX450 gateway has a Serial I/O X-Card installed:
 - Small adjustable torque wrench
 - 4 mm nut driver or socket that works with the torque wrench
- If your gateway has a Wi-Fi X-Card installed:
 - Small adjustable torque wrench
 - 8 mm socket—long enough to fit over the SMA antenna connector

The procedure for installing a SIM card varies depending on whether or not the gateway has an X-Card installed, and if so, the type of X-Card present. Follow the appropriate instructions for your gateway:

- [Installing the SIM Card—No X-Card present](#) on page 15
- [Installing the SIM Card—Wi-Fi X-Card present](#) on page 16
- [Installing the SIM Card—I/O X-Card present](#) on page 19
- [Installing the SIM Card—Dual Ethernet X-Card present](#) on page 22

Installing the SIM Card—No X-Card present

- 1) Remove the four screws attaching the cover.
Save the screws for reinstallation.

- 2) Remove the cover.

- 3) Slide the SIM card into the SIM card holder.

Note the direction of notched corner of SIM card for proper alignment.

- 4) Use the screws you saved in step 1 to reattach the cover. Torque the screws to 5 in-lb. (0.6 N-m).

Figure 2-1: SIM Card Installation, with no X-Card present

Installing the SIM Card—Wi-Fi X-Card present

Important: Failure to follow these instructions carefully may damage the X-Card and void the warranty agreement.

To install a SIM card in a GX450 gateway with a Wi-Fi X-Card installed:

1. Unscrew the 8 mm hexagonal nut on the Wi-Fi SMA antenna connector at the front of the gateway, using the socket and wrench. Then slide off the nut and lock washer. Save the nut and washer. These are used again.
2. Remove the four screws used to secure the black decorative cover. Use a 2 mm Allen (hex) wrench or a Phillips #1 screwdriver, depending on the screw type used on the black decorative cover. Save the screws for reinstallation.

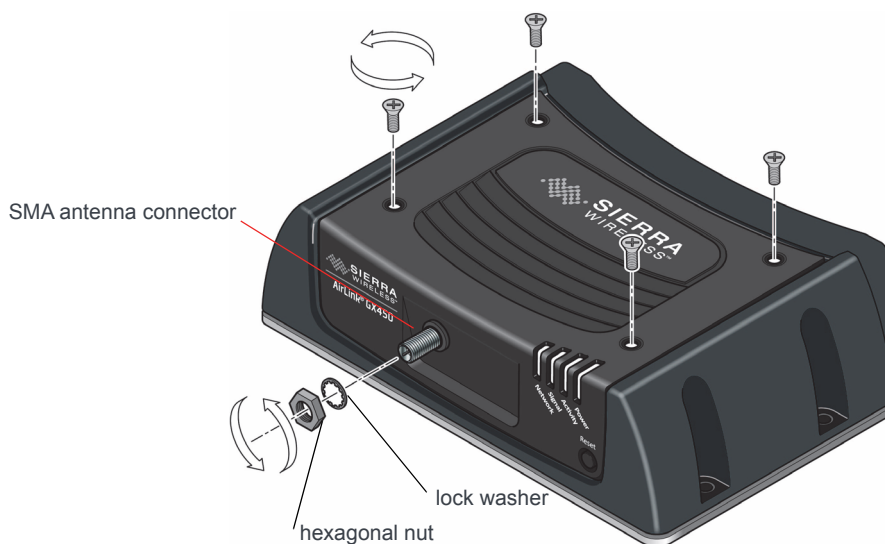
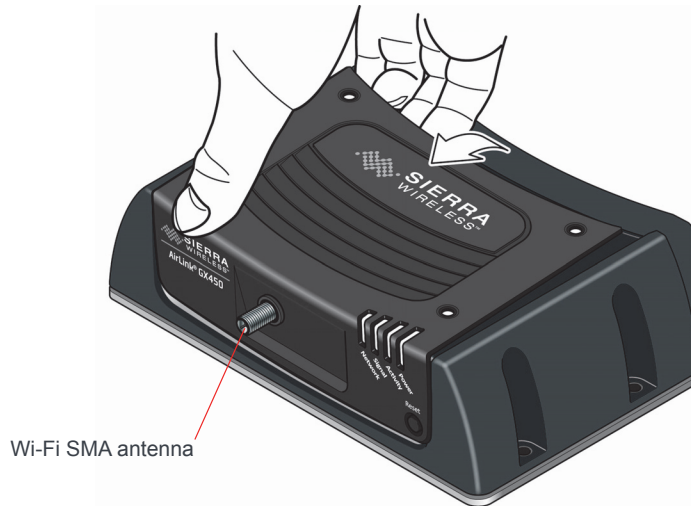

Figure 2-2: Removing the screws, nut and washer (Wi-Fi X-Card installed)

3. Gently tilt up the back of the decorative black cover and then move the cover forward so that it slides over the Wi-Fi SMA antenna connector.



Wi-Fi SMA antenna

Figure 2-3: Tilting the cover (Wi-Fi X-Card installed)

4. Continue to slide the cover horizontally until it clears the SMA antenna connector.

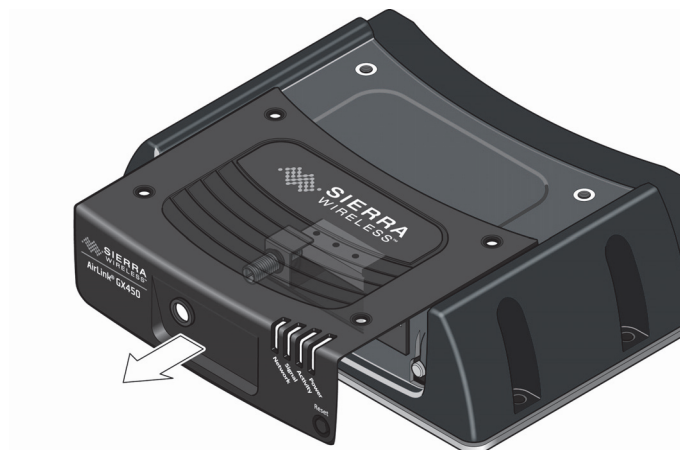
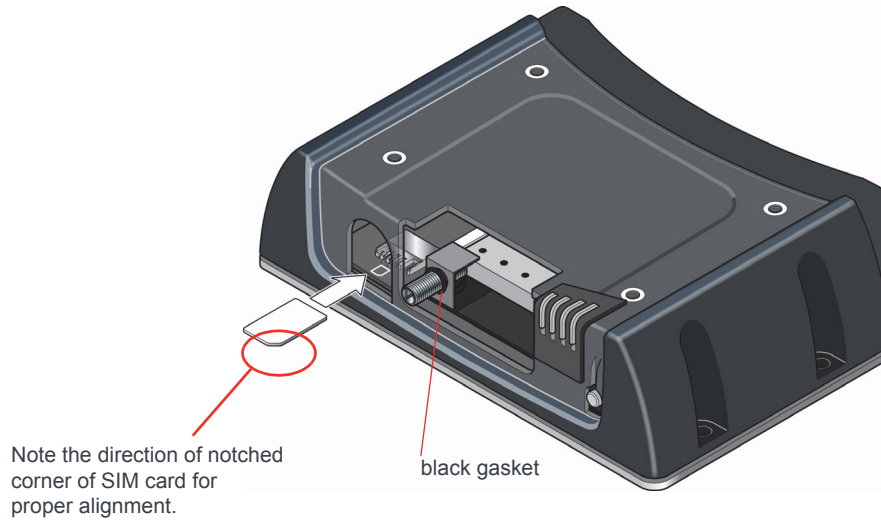

Figure 2-4: Removing the cover (Wi-Fi X-Card installed)

5. Lift the cover to remove it completely. Save the cover. It is used later.
6. Insert the SIM card, with the gold contacts facing down and the notch on the right side, as shown in the following illustration.



Note the direction of notched corner of SIM card for proper alignment.

black gasket

Figure 2-5: Inserting the SIM card (Wi-Fi X-Card installed)

7. Ensure the black gasket is in place at the base of the SMA antenna connector.
8. Re-install the decorative black cover:
 - a. Line up the SMA antenna connector with the hole in the cover.
 - b. Tilt the rear of the cover slightly to make sure the front bottom of the cover seats in the front ridge. Slide the cover into place, and then push the top of the cover down.

It may require some force to make sure the four holes in the cover line up with the threaded holes on the top of the gateway. You may need to push from the front as well to ensure that the holes line up properly.
9. Use the four screws saved in step 2 to re-attach the decorative black cover. Torque the screws to 5 in-lb. (0.6 N-m). Ensure that the screws are tight so that the seal underneath the decorative black cover is tight against the gateway.

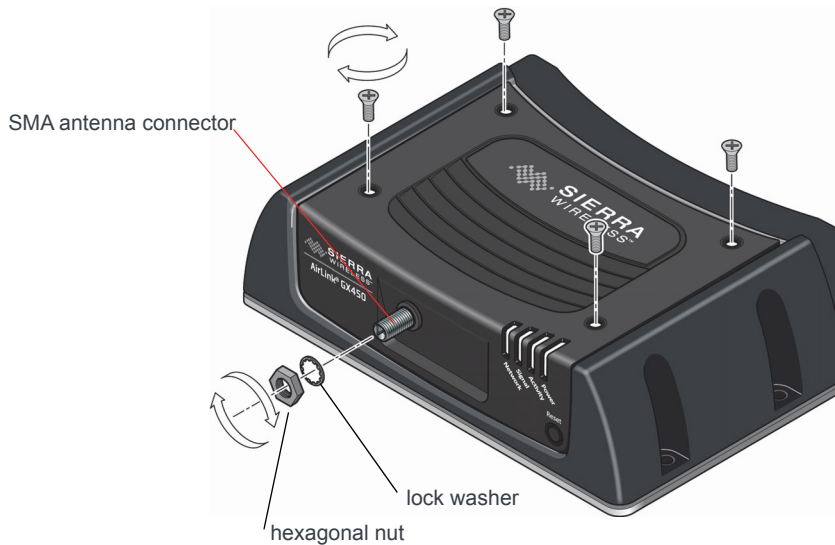

Figure 2-6: Replacing the screws, nut, and washer (Wi-Fi X-Card installed)

10. Place the lock washer onto the SMA antenna connector and move it to the back of the connector, so it is touching the decorative black cover.
11. Install, then tighten the nut with a 5/16" or 8 mm socket torque wrench to a torque specification of 8 in-lbs (0.9 N-m).

Installing the SIM Card—I/O X-Card present

Important: *Failure to follow these instructions carefully may damage the X-Card and void the warranty agreement.*

To install a SIM card in a GX450 gateway with an I/O X-Card installed:

1. Unscrew the two 4-40 male to female hexagonal threaded standoffs (jack screws) on either side of the serial port at the front of the gateway, using the socket and wrench. Keep the hexagonal threaded standoffs for reinstallation.
2. Remove the four screws used to secure the black decorative cover. Use a 2 mm Allen (hex) wrench or a Phillips #1 screwdriver, depending on the screw type used on the decorative black cover. Save the screws for reinstallation.

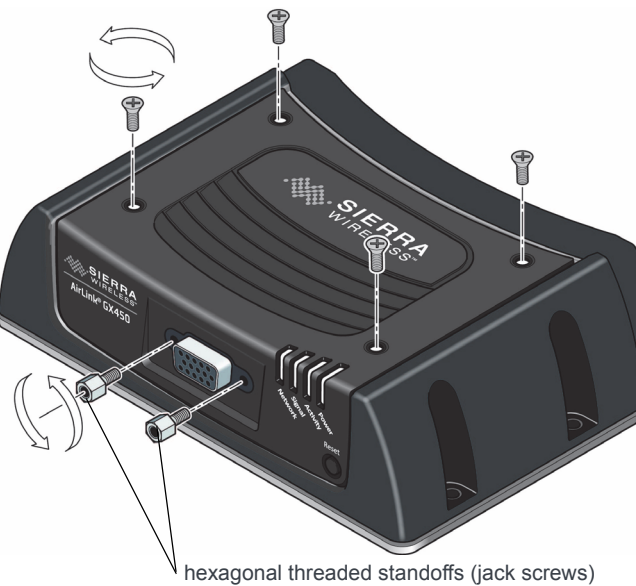

Figure 2-7: Removing the screws and threaded standoffs (I/O X-Card installed)

3. Gently tilt up the back of the decorative black cover and then move the cover forward so that it slides over the serial port.



Figure 2-8: Tilting the cover (I/O X-Card installed)

4. Continue to slide the cover horizontally until it clears the serial port.

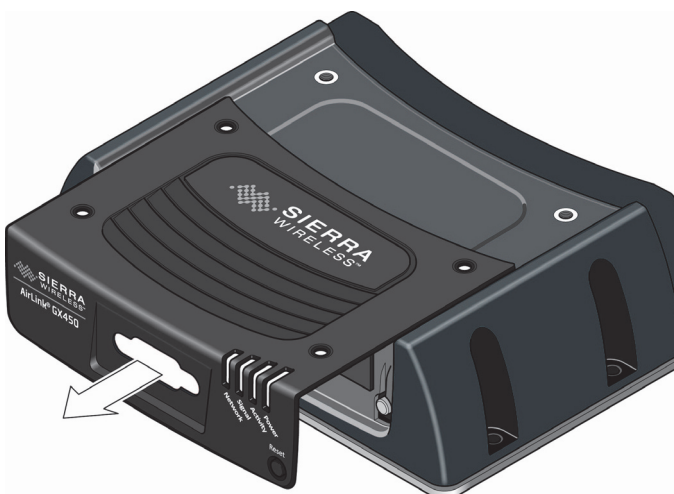
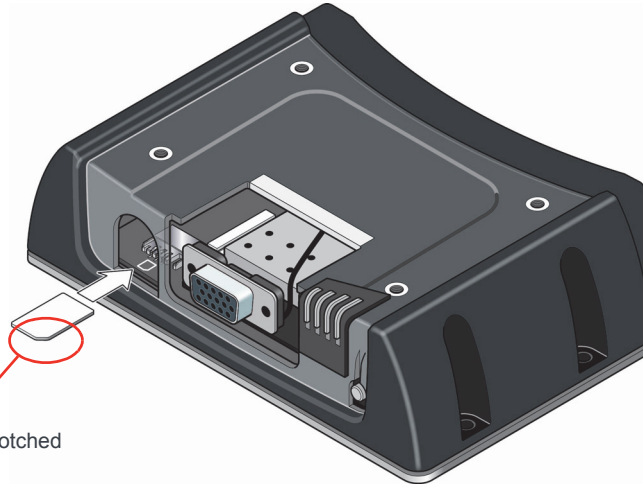

Figure 2-9: Removing the cover (I/O X-Card installed)

5. Lift the cover to remove it completely. Save the cover. It is used again.
6. Insert the SIM card, with the gold contacts facing down and the notch on the right side, as shown in the following illustration.



Note the direction of notched corner of SIM card for proper alignment.

Figure 2-10: Inserting the SIM card (I/O X-Card installed)

7. Install the decorative black cover:
 - a. Line up the serial port with the hole in the cover.
 - b. Tilt the rear of the cover slightly to make sure the front bottom of the cover seats in the front ridge. Slide the cover into place, and then push the top of the cover down.

It may require some force to make sure the four holes in the cover line up with the threaded holes on the top of the unit. You may need to push from the front as well to ensure that the holes line up properly.
8. Use the four screws you saved in step 2 to re-attach the decorative black cover. Torque the screws to 5 in-lb. (0.6 N-m). Ensure that the screws are tight so that the seal underneath the decorative black cover is tight against the gateway.
9. Re-install the screw nuts you saved in step 1 to either side of the serial port. (Finger tight is sufficient.)

Note: The screw nuts must be re-installed to maintain the IP rating for the AirLink gateway.

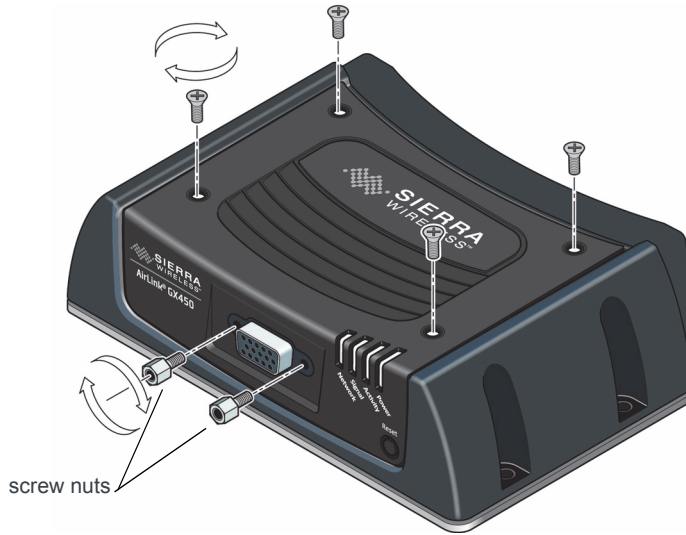

Figure 2-11: Replacing the screws and nuts (I/O X-Card installed)

Installing the SIM Card—Dual Ethernet X-Card present

Important: Failure to follow these instructions carefully may damage the X-Card and void the warranty agreement.

To install a SIM card in a GX450 gateway with a Dual Ethernet X-Card installed:

1. Remove the four screws used to secure the black decorative cover. Use a 2 mm Allen (hex) wrench or a Phillips #1 screwdriver, depending on the screw type used on the black decorative cover. Save the screws for reinstallation.

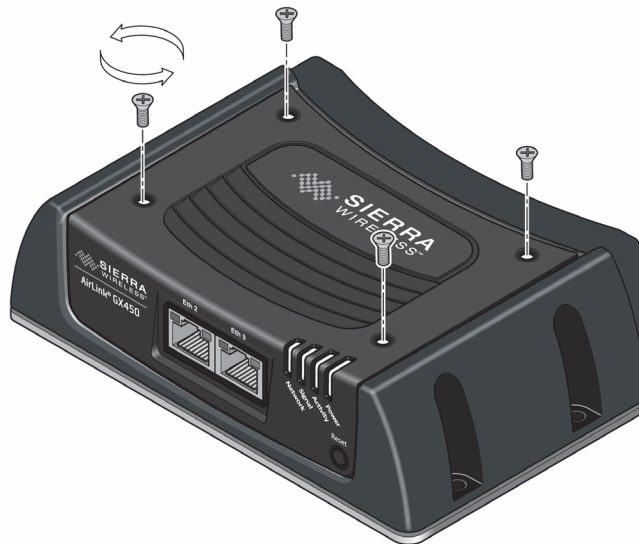

Figure 2-12: Removing the screws (Dual Ethernet X-Card installed)

2. Gently tilt up the back of the decorative black cover and then move the cover forward so that it slides over the Ethernet ports, being careful not to damage the rubber gasket.



Figure 2-13: Tilting the cover (Dual Ethernet X-Card installed)

3. Continue to slide the cover horizontally until it clears the Ethernet ports.

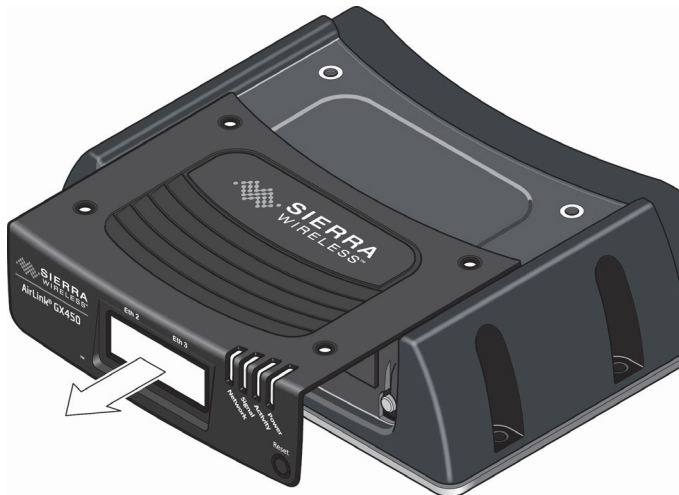

Figure 2-14: Removing the cover (Dual Ethernet X-Card installed)

4. Lift the cover to remove it completely. Save the cover. It is used again.
5. Insert the SIM card, with the gold contacts facing down and the notch on the right side, as shown in the following illustration.

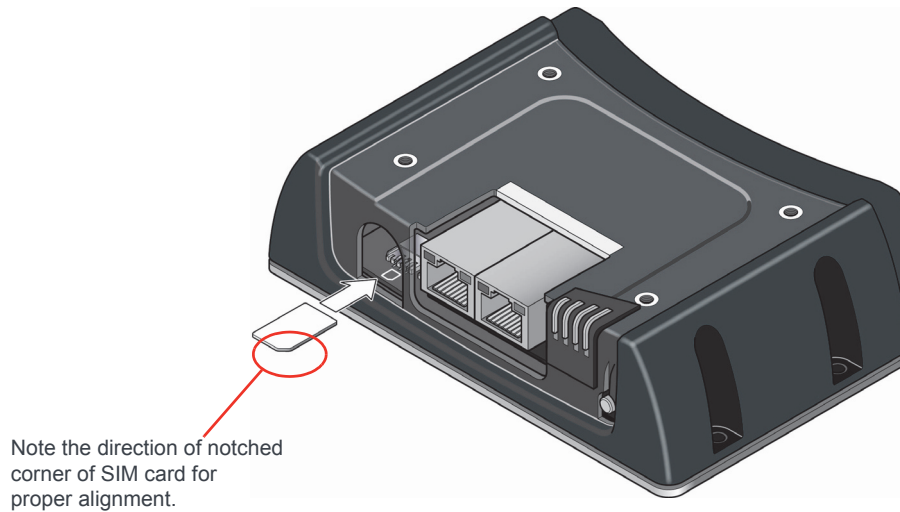

Figure 2-15: Inserting the SIM card (Dual Ethernet X-Card installed)

- 6.** Install the decorative black cover:
 - a.** Line up the Ethernet ports with the hole in the cover.
 - b.** Tilt the rear of the cover slightly to make sure the front bottom of the cover seats in the front ridge. Slide the cover into place, and then push the top of the cover down. Ensure that the black gasket around the Ethernet ports is snug, with no gaps, and that the gasket is not folded in on itself.

It may require some force to make sure the four holes in the cover line up with the threaded holes on the top of the unit. You may need to push from the front as well to ensure that the holes line up properly.
- 7.** Use the four screws saved in step 1 to re-attach the decorative black cover. Torque the screws to 5 in-lb. (0.6 N-m). Ensure that the screws are tight so that the seal underneath the decorative black cover is tight against the gateway.

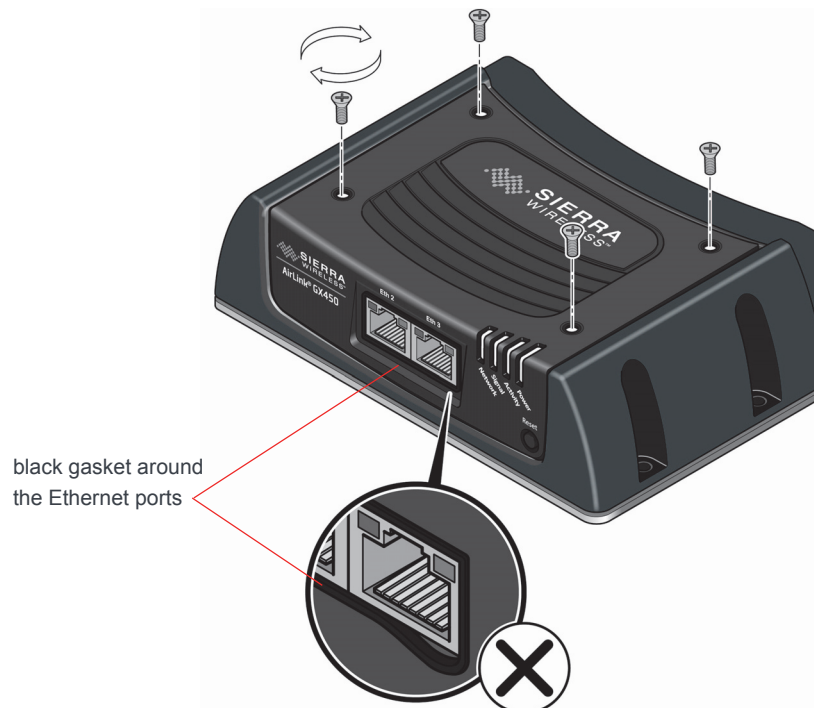

Figure 2-16: Replacing the screws (Dual Ethernet X-Card installed)

Mounting the GX450

Warning: This gateway is not intended for use close to the human body. Antennas should be at least 8 inches (20 cm) away from the operator.

Note: The gateway has a hardened case for use in industrial and extreme environments. If you are installing it in these types of environments, use cables designed and specified for use in these types of environments to avoid cable failure.

Mount the gateway where:

- There is easy access to the cables
- Cables are not bent, constricted, close to high amperages or exposed to extreme temperatures
- Cables are secured to ensure reliable connections
- The front panel LEDs are easily visible
- There is adequate airflow
- It is kept free from direct exposure to the elements, such as sun, rain, dust, etc.

In addition to the four mounting holes on the side of the gateway's body, there are four holes on the bottom plate to attach the gateway to a mounting surface.

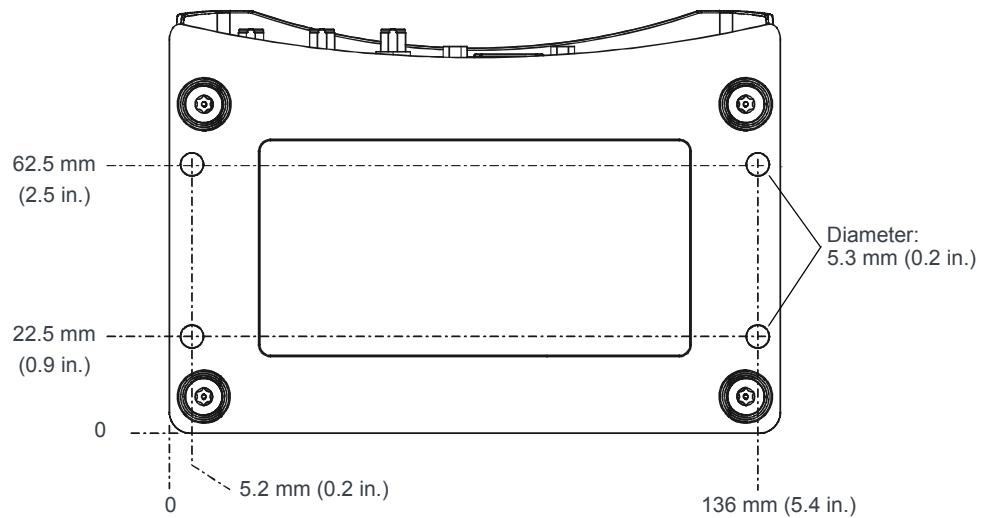

Figure 2-17: GX450 Bottom Plate and Mounting Holes

Grounding the GX450 Gateway Chassis

For DC installations (with a fixed “system” ground reference), Sierra Wireless recommends always grounding the GX chassis or the mounting bracket to the system ground reference. To ensure a good grounding reference, use a short wire with a gauge of 18 AWG or larger connected to one of the mounting holes with the screws and lock washers provided in the supplied mounting kit.

Vehicle Mounting

The AirLink GX450 gateway must be installed by qualified personnel in accordance with the vehicle manufacturer’s specifications.

When installing the gateway in a vehicle:

- Keep it out of direct exposure to the weather (sun, rain, etc.). The best locations are in places like a car trunk or in a container behind the seats.
- Place it where it will not be bumped or come into contact with people, cargo, tools, equipment, etc.

For information on connecting the power, see [Connecting a DC Power Cable](#) on page 32.

Antenna Installation

Inadequate antenna separation between the transmit and diversity antennas creates unwanted interactions. This can cause reductions in:

- Antenna efficiency
- Transmit power
- Receiver sensitivity
- Data throughput
- Radio front-end life span

Antenna Separation Recommendations

- The antennas should be separated so that there is at least 10 dB isolation over the entire operating frequency range.
- The separation should be at least 1/4 wavelength (λ), but preferably 1/2 wavelength or greater of the lowest operating frequency. See [Table 2-1](#) for specific recommendations, based on your network service type and frequency.

Note: The values in the table are approximate antenna separation values for monopole or dipole type antennas.

Table 2-1: Recommended Antenna Separation

Service	Frequency (MHz)	Wavelength (λ) (mm)	Best Antenna Separation (mm) ($1/2 \lambda$)	Good Antenna Separation (mm) ($1/4 \lambda$)
LTE	700	428	214	107
LTE	800	375	187	94
LTE	900	333	167	83
LTE	1800	167	83	42
LTE	2100	143	71	36
LTE	2600	115	58	29
WCDMA	850	353	176	88
WCDMA	900	333	167	83
WCDMA	1900	158	79	39
WCDMA	2100	143	71	36
CDMA/EV-DO	800	375	187	94
CDMA/EV-DO	1900	158	79	39
GSM/GPRS/EDGE	850	353	176	88
GSM/GPRS/EDGE	900	333	167	83
GSM/GPRS/EDGE	1800	167	83	42
GSM/GPRS/EDGE	1900	158	79	39

Table 2-2: Separation Examples for Specific Mobile Network Operator Bands

Service	Band	Mobile Network Operator	Country	Min Frequency (MHz)	Wavelength (λ) (mm)	Best Antenna Separation (mm) ($1/2 \lambda$)	Good Antenna Separation (mm) ($1/4 \lambda$)
LTE	13	Verizon	US	746	401.8665657	201	100
LTE	17	AT&T	US	704	425.8415597	213	106
LTE	4	Bell/Rogers/Telus	Canada	1710	175.3172269	88	44

Antenna Recommendations

Note: Do not remove the diversity antenna. The diversity antenna helps the gateway achieve the maximum network coverage. The gateway works without one installed, but with reduced network coverage.

Note: If the antennas are located far away from the gateway, keep the cables as short as possible to prevent the loss of antenna gain.

Warning: *The antenna should not exceed the maximum gain specified in [Maximum Antenna Gain \(Gain D'antenne Maximal\)](#) on page 62. In more complex installations (such as those requiring long lengths of cable and/or multiple connections), you must follow the maximum dBi gain guidelines specified by the radio communications regulations of the Federal Communications Commission (FCC) or Industry Canada or your country's regulatory body (if used outside the US). Also see [Important Information for North American Users on Radiation Exposure](#) on page 61 for more information.*

Mounting the GPS Antenna

Mount the antenna where it has a good view of the sky such as on the roof, the dashboard or the rear panel. It should see at least 90° of the sky.

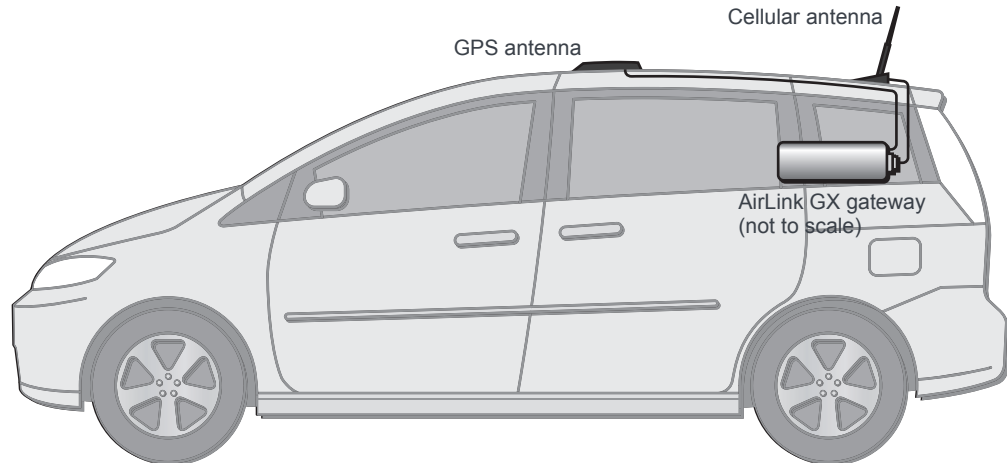

Figure 2-18: Mounting the GPS Antenna

Connecting the GX450 Gateway

Note: Route cables so that they are protected from damage and will not be snagged or pulled on. There should be no binding or sharp corners in the cable routing. Excess cabling should be bundled and tied off. Make sure the cables are secured so their weight will not loosen the connector from the gateway over time.

1. Connect the RF antenna to the antenna connector.
2. If used, connect the GPS antenna to the GPS antenna connector.
3. Connect an RF antenna to the Diversity/AUX antenna connector.
4. Connect the power cable to the gateway, and if used, to the external devices to be controlled/monitored.
5. Attach a laptop to the gateway with the Ethernet cable.

Note: For details about the power connector, see [Connecting a DC Power Cable](#) on page 32. The battery connector cable should be no longer than 10 feet (3 meters).

The gateway starts automatically as soon as it receives power. If it fails to start, ensure that the:

- Power connector is plugged in
 - Power cable is connected to power (line or battery power)
 - Power is turned on or that the battery is fully charged
 - Ignition Sense (pin 3) is connected to the battery or power source (see [Connecting a DC Power Cable](#) on page 32 for details)
6. If used, attach a gateway or computer to the RS-232 port and/or the USB port.

For information on configuring the GX450 gateway, see [Configuring AirLink GX450 Gateways](#) on page 44.

LED Operation

Power-up and Reboot

On power-up or reboot, all LEDs turn red, then amber, then green. They then go through a blinking sequence that ends with the Power LED green and all the other LEDs off. Once the other LEDs resume their normal operating behavior, the reboot is complete.

To reboot the gateway:

- In ACEmanager, click the Reboot button at the top right of the screen.
- Press and release the Reset button on the gateway (see [Front Panel](#) on page 8). Do not hold the button down for more than a few seconds. (If you hold it for 7–10 seconds, the gateway resets to factory default settings.)

LED Behavior

Table 2-3: LED Behavior

LED	Color / Pattern	Description
Power	Off	No power or input voltage ≥ 36 VDC or ≤ 9 VDC
	Solid Green	Gateway is connected to nominal power and is operating normally.
	Flashing Amber / Green	Gateway has a GPS fix
	Solid Amber	Gateway is entering low power mode or system low level boot.
	Solid Red	Gateway is not operational (failure or in low power mode).
Signal	Solid Green	Good signal (RSSI ≥ -85 dBm)
	Solid Amber	Marginal signal (-100 dBm $<$ RSSI $<$ -85 dBm)
	Solid Red	Poor signal (-110 dBm \leq RSSI \leq -100 dBm)
	Flashing Red	No signal (RSSI $<$ -110 dBm)

Table 2-3: LED Behavior

LED	Color/Pattern	Description
Network	Solid Green	Connected to an LTE network
	Flashing Amber/Green	Network Ready—No LTE service available
	Flashing Green (3 sec. on/1 sec. off)	Network Ready—WAN over Wi-Fi (gateway in Wi-Fi client mode)
	Flashing Green (1 sec. on/0.5 sec. off)	Network Ready—Roaming (LTE service available)
	Flashing Amber/Green/Off	Network Ready—Roaming (No LTE service available)
	Flashing Amber	No Service
	Solid Amber	Connected to a 3G or 2G network
	Flashing Red	Authentication/Negotiation failed (EV-DO only)
	Solid Red	Link Down No cellular network is present, no network coverage at current location, or the gateway is in radio passthru mode
	Flashing Red/Amber	The gateway is unable to locate the required radio module firmware. You must upgrade the radio module firmware for the gateway. For more information, refer to the ALEOS Software Configuration User Guide.
Activity	Off	Normal operation
	Flashing Green	Traffic is being transmitted or received over the WAN interface.
	Flashing Red	Traffic is being transmitted or received over the serial port. (This behavior only appears if the AirLink gateway is configured to display it. Refer to the ALEOS Software Configuration Guide for details.)
	Flashing Amber	Traffic is being transmitted or received over both the WAN interface and the serial port. (This behavior only appears if the AirLink gateway is configured to display it. Refer to the ALEOS Software Configuration Guide for details.)
ALL LEDs	Solid Amber	When you press the reset button for more than 20 seconds, all the LEDs turning solid amber indicates when to release the reset button to enter Recovery mode. (See Recovery Mode on page 47.)
	Solid Red	When you press the reset button for 7–10 seconds, all the LEDs turning solid red indicates when to release the reset button to reset the gateway to the factory default settings. (See Reset to Factory Default Settings on page 47.)
	Heartbeat Pattern	When the gateway is in Recovery mode, all LEDs flash red once, then turn off one at a time. See Recovery Mode on page 47.

Ethernet LEDs

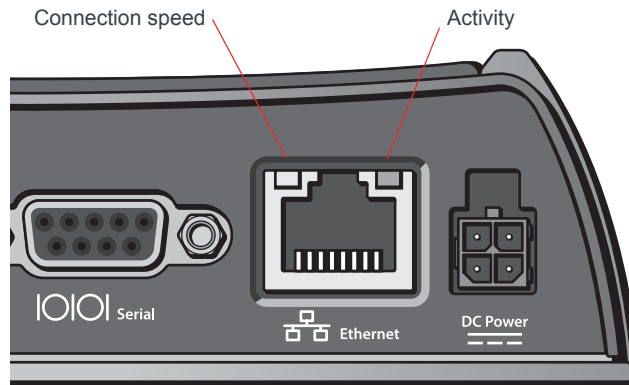

Figure 2-19: Ethernet LEDs

The Ethernet connector has two LEDs that indicate speed and activity. When looking into the connector:

- **Activity**—The right LED is solid amber when a link is detected (the cable is plugged in) and blinks when there is activity.
- **Connection Speed**—The left LED is green to indicate a 100 Mbps connection and orange to indicate a 10 Mbps connection. It is off when no cable is connected.

Power-up and Reboot

On power-up or reboot, the LEDs go through a booting sequence. When the boot is complete, the Power and Network LEDs should be green, signifying that the power is on, the GX450 gateway is connected to the wireless network, and there is a good signal. See [Table 2-3](#) on page 30 for detailed LED operation.

To reboot the GX450 gateway, either:

- In ACEmanager, click the Reboot button at the top right of the screen.

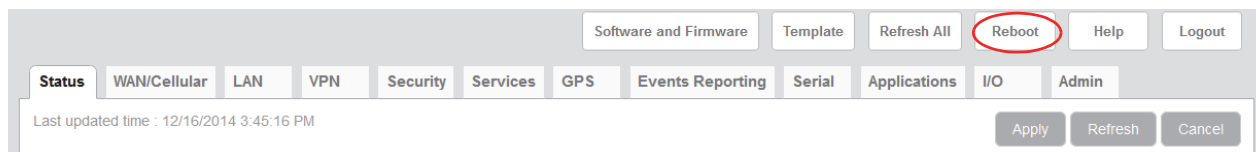

Or

- Press and release the Reset button on the GX450 gateway (see [Front Panel](#) on page 8).

Connecting a DC Power Cable

The GX450 gateway has a four-pin power connector that has:

- Two pins connecting DC voltage to the gateway
- Two pins providing additional monitoring and control functions

Fusing

For DC installations, Sierra Wireless recommends fusing the power input using a 2.0 A fast-acting fuse. Install the fuse on the positive line, as shown in [Figure 2-20](#) on page 34. For vehicle installations, use an automotive fuse.

Power Supply Conditioning

For automotive applications, the supply voltage may momentarily drop below 9.0 V during engine cranking, causing the GX450 gateway to reboot. If this happens, the gateway restarts automatically and is ready for use once the reboot is complete. If your application requires the gateway to continue operating during engine cranking, add external power conditioning circuits to ensure the supply voltage does not drop below the rated value (9.0 V).

Power Connector on the GX450 Gateway

If you are using the DC power cable to connect the gateway to a power source:

- **Pin 1**—Use the red wire in the DC cable to connect Pin 1 to the power source. Include a 2.0 A fast-acting fuse in the input power line. Sierra Wireless recommends using a continuous (unswitched) DC power source. For installations that require the device to be turned on/off, Sierra Wireless recommends using the Ignition Sense (Pin 3) input for this purpose.

Note: When the gateway switches to Low Power mode based on a Low Voltage trigger, the voltage is monitored on the Red, Power wire.

- **Pin 2**—Use the black wire in the DC cable to connect Pin 2 to ground. See also [Grounding the GX450 Gateway Chassis](#) on page 26.
- **Pin 3 (Ignition Sense)**—Sierra Wireless recommends always using the Ignition Sense wire to turn the gateway off. It should not be turned off by disconnecting the power. For installations where the GX450 gateway is turned on/off, use the white wire in the DC cable connected to Pin 3 to:
 - Turn the gateway on/off with the vehicle ignition

Note: To turn the gateway on/off with the vehicle ignition, Sierra Wireless strongly recommends using an unswitched VCC on Pin 1 (Red, Power wire on DC cable) with Pin 3 (White, Ignition sense wire on DC cable) connected to the ignition.

- Turn the gateway on/off with a low voltage disconnect device

Note: To turn the gateway off when the voltage drops below a defined level, connect Pin 3 to an external low voltage disconnect. See [Figure 2-20](#) on page 34.

- **Pin 4 (General Purpose I/O) (Optional)**—Use the green wire in the DC cable to connect Pin 4 to a switch or relay on an external device you want to monitor. For more details, see [page 35](#).

See [Figure 2-20](#) and [Table 2-4](#).

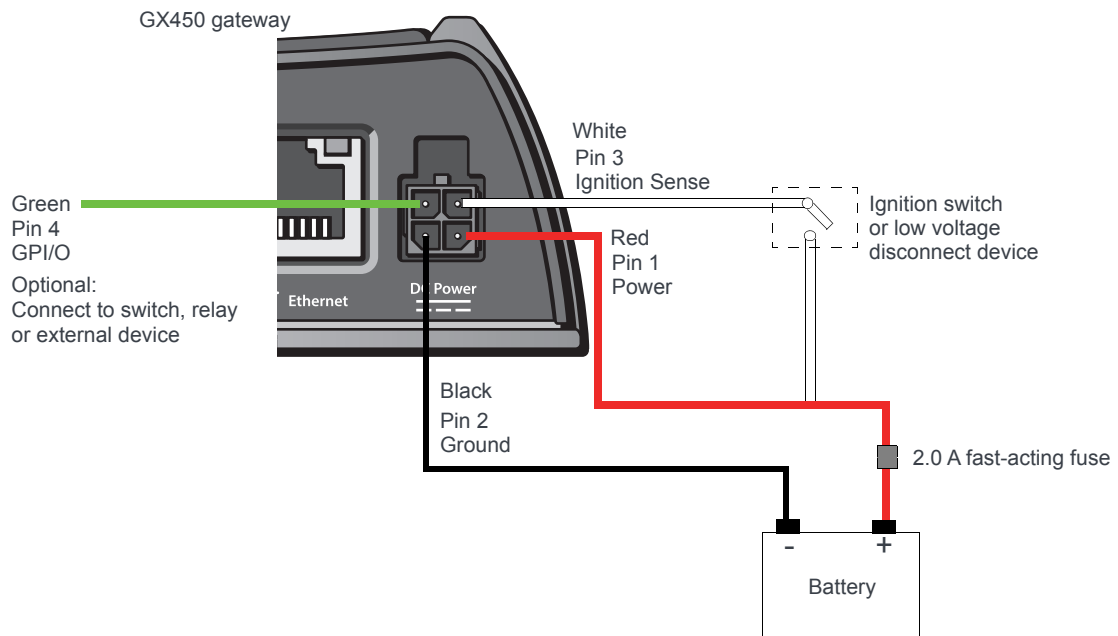

Figure 2-20: DC power cable connections (Colors indicate DC cable wire colors.)

Table 2-4: Power Connector Pin and DC cable Wires

Pin	Name	Associated DC Cable Wire Color	Description	Type
1	Power	Red	Main power supply for device	PWR
2	GND	Black	Main device ground	PWR
3	IGN Sense	White	<p>Ignition Sense: Connected to the vehicle ignition or an external low voltage disconnect device.</p> <p>Voltage thresholds:</p> <ul style="list-style-type: none"> Input low (max.) = 2 V Input high (min.) = 3 V <hr/> <p><i>Note: If you do not connect pin 3 to the ignition, you MUST connect it to the positive terminal of your power supply or battery. If you are using a Sierra Wireless AC adapter, the connection is inside the cable.</i></p> <hr/> <p>For more information, see Power Connector on the GX450 Gateway on page 33.</p>	I
4	GPIO	Green	User configurable digital input/output or analog voltage sensing input. Connect to switch, relay or external device. Maximum rating is 30 V, 150 mA. For more information, see Pin 4 (General Purpose I/O) on page 35 and the ALEOS Software Configuration User Guide.	I/O

Pin 4 (General Purpose I/O)

This pin is a digital input/output (green wire on DC cable).

Pin 4 either:

- Monitors digital inputs and outputs
- Drives a relay

It has a maximum rating of 30 V and 50 mA sink current. The pin is user programmed. For information on configuring Pin 4 (Digital Input/Relay Output 1 in ACEmanager) refer to the ALEOS Software Configuration User Guide.

One way to use pin 4 is with events reporting. In ACEmanager you:

1. Create an Event.

This triggers the gateway to act when it sees a specific input. For example, you can tell the gateway to do something when the Pin 4 state (Digital Input/Relay Output 1 in ACEmanager) changes. This could be when a door is opened, activating a switch attached to it.

2. Specify an Action.

These are instructions the gateway performs when it sees an event. For example, an email could be sent to security, saying the door is open, giving the time, location and other information.

There are several typical uses for Pin 4:

- As a digital input, it monitors a switch, using its opening or closing to record events or monitoring external voltages of up to 30 VDC. For example, you could use it to measure the voltage on a 24 VDC light bulb and have the gateway react when it turns on.

When the switch, or input voltage is:

- Open (2.2 VDC to 30 VDC) – It is read as a digital input = 1
- Closed (0 to 1.2 VDC) – It is read as a digital input = 0

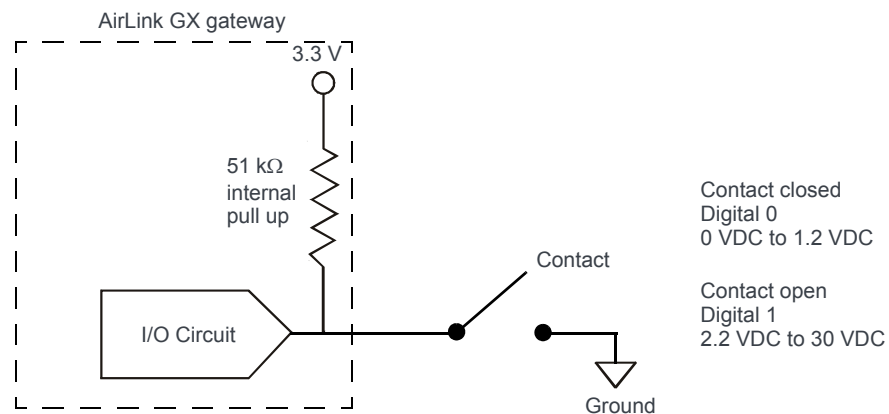

Examples: Door opening/closing, valve opening/closing, ignition on/off, tow bar up/down, empty/full container.

Figure 2-21: Digital Input Operation

- As a digital output, it can trigger an alarm, siren, door lock or open a valve or a switch. Pin 4 is an open collector transistor output normally at 3.3 VDC. When triggered, it is pulled to low.

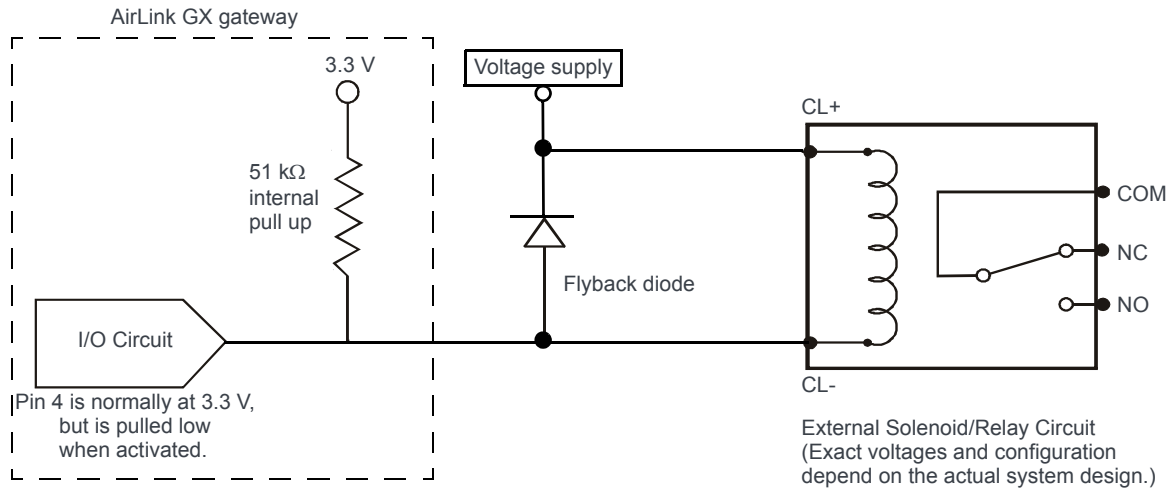

Figure 2-22: Digital Output Operation

Note: Some solenoids/relays include a flyback diode built into the unit. For those that do not, Sierra Wireless recommends a flyback diode with a voltage rating at least double the relay voltage and a current rating at least double the relay ON current to avoid damage to the GX input. A common 1N4007 will work for most applications. See Table 2-7 on page 40.

The initial state of the digital output when the gateway is rebooted is configurable in ACEmanager.

Serial Port

You can connect the GX450 gateway's 9-pin serial connector directly to most computers or other devices with a standard straight-through cable. This connector is used for gateway configuration and debugging.

This connector complies with the EIA RS-232D specification for DCE equipment. The output driver levels swing from -7 VDC to +7 VDC with normal loading.

Note: If you have a DCE device, you need to use a null modem cable.

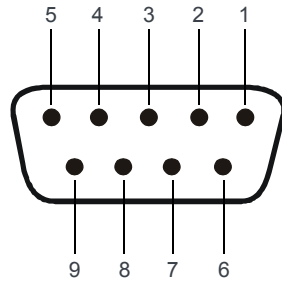

Figure 2-23: 9-Pin Serial Connector Diagram

Table 2-5: Serial Connector Pin-out

Name	Pin	Description	Type
DCD	1	Data Carrier Detect	OUT
RXD	2	Receive Data	OUT
TXD	3	Transmit Data	IN
DTR	4	Data Terminal Ready	IN
GND	5	Main GND. Connected internally to BOARD_GND	GND
DSR	6	Data Set Ready	OUT
RTS	7	Ready To Send	IN
CTS	8	Clear To Send	OUT
RI	9	Ring Indicator	OUT

X-Cards

The AirLink GX450 has several optional, factory-installed, expansion cards (X-Cards) available to add more functions to the basic gateway. They are configurable with ACEmanager and more information is available in the ALEOS Software Configuration User Guide, which is available for downloading from the Sierra Wireless web site.

The available X-Cards are:

- Wi-Fi
- I/O
- Dual Ethernet

If you have an X-Card installed in your gateway, its type and status is shown on the ACEmanager home page (Status > Home).

Wi-Fi X-Card

This card adds Wi-Fi capacity to the gateway using the 802.11b/g/n standard. It has the following modes:

- Client Mode where the gateway uses a Wi-Fi client connection to connect to an access point, rather than acting as an access point (AP)
- Access Point Mode where the gateway acts as an AP
- Both (AP + Client Mode) where the gateway can act as an AP and also use a Wi-Fi Client connection to connect to an AP

The GX450 gateway connects as a client to a configured AP whenever the AP is available. When the AP is not available, it connects to a 3G network and acts as an AP to Wi-Fi clients connected to the GX.

Note: The Wi-Fi X-card requires the use of an antenna with a male RP-SMA connector.

See the ALEOS Software Configuration User Guide for details on Wi-Fi configuration and use.

I/O X-Card

This card uses a 15-pin connector to add to the basic gateway:

- One additional RS-232 communication port
- Four additional digital I/O pins
- Four analog voltage sensing pins
- Optional 2 meter I/O X-Card breakout cable (to order, contact your distributor)

Maximum data rate for the RS-232 interface on the I/O X-Card is 115.2 kbps.

See the ALEOS Software Configuration User Guide for details on I/O setup and use.

I/O X-Card 15-Pin Connector Description

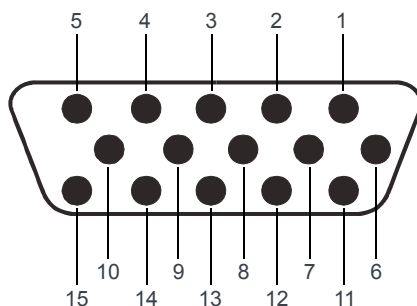

Figure 2-24: I/O X-Card 15-pin Connector Pin Diagram

Note: For better performance, signal pins on the I/O X-Card should be referenced to the ground pin on the I/O X-Card (pin 10).

An optional 2-meter 15-pin I/O breakout cable (pn 2000424) for use with the I/O X-card is available from distributors.

Table 2-6: I/O 15-Pin Connector Pin Description

Pin	Name	Description	Wire color (on optional I/O X-Card breakout cable)
1	TXD	Transmit Data	White/Black
2	CTS	Clear to Send	Red/Black
3	DIO[2]	Digital I/O 2	Green/Black
4	DIO[4]	Digital I/O 4	Orange/Black
5	RXD	Receive Data	Blue/Black
6	RTS	Request to Send	Blue
7	AIN[2]	Analog Input 2	Green
8	AIN[4]	Analog Input 4	Red
9	Reserved for future use		Black
10	GND	Ground	White
11	DIO[3]	Digital I/O 3	Orange
12	DIO[5]	Digital I/O 5	Blue/White
13	Reserved for future use		Green/White
14	AIN[1]	Analog Input 1	Red/White
15	AIN[3]	Analog Input 3	Black/White
Shield	Cable Shield		
This is not a VGA connector			
<hr/>			
<i>Note: Digital Input 1 in ACEmanager is reserved for Pin 4 on the power connector.</i>			
<hr/>			

To check the current digital input values:

- In ACEmanager, go to I/O > Current State.

Digital I/O Interface

There are four digital I/O pins on the high density DB15 connector. Typical applications are:

- Input—source is a dry switch contact to ground
- Output—to drive a relay coil to ground
- Analog—to detect voltage levels in input or output mode

Pins include a 51 k Ω pull up to 2.8 VDC.

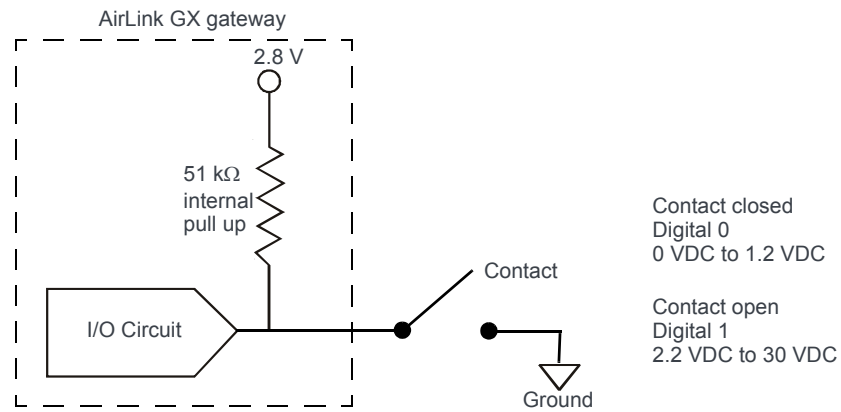

Examples: Door opening/closing, valve opening/closing, ignition on/off, tow bar up/down, empty/full container.

Figure 2-25: Digital Input Operation

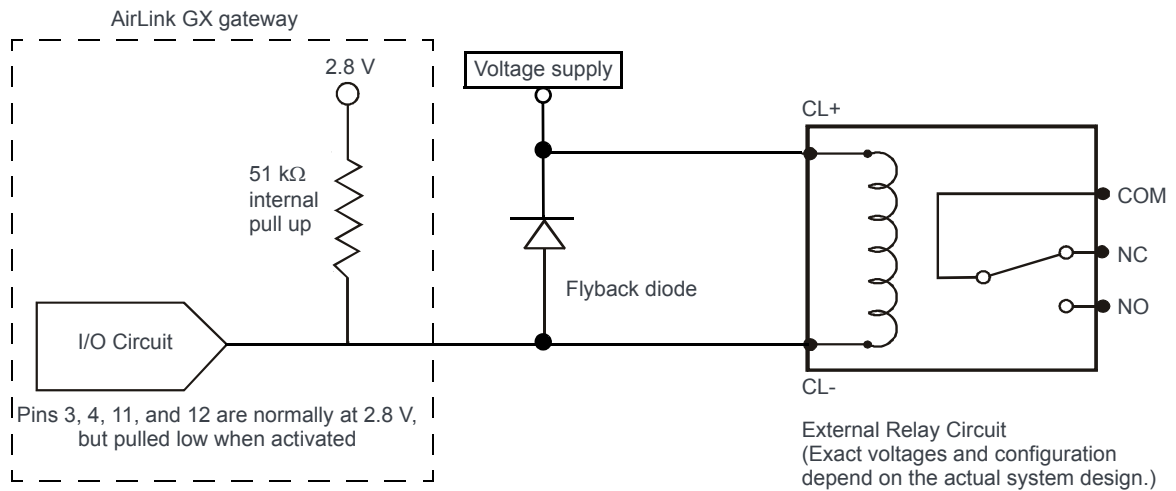

Pins 3, 4, 11, and 12 are normally at 2.8 V, but pulled low when activated

Figure 2-26: Digital Output Operation

Table 2-7: Digital I/O

Pins	Name	Specification	Min	Typical	Max	Units
3 4 11 12	DIO[2...5] (as input)	Input low state voltage (At or below this voltage, relay reads as low)	—	—	1.2	V
		Input high state voltage range (At or above this voltage, relay reads as high)	2.2	—	—	V
		Input leakage current at 5 V	—	0.05	—	mA
		Input leakage current at 12 V	—	1.8	—	mA
		Input leakage current at 24 V	—	5.5	—	mA
3 4 11 12	DIO[2...5] (as output)	Open drain drive to ground	—	100	—	mA
		Maximum open circuit voltage applied	—	—	30	V

I/O X-Card Digital I/O Input Pins

Pins 3, 4, 11 and 12 are programmed in ACEmanager to monitor inputs, respond to certain types of events or trigger a digital output. They behave exactly like the Digital I/O (pin 4) on the power connector as described in [Connecting a DC Power Cable](#) on page 32.

Note: Digital Input 1 in ACEmanager is reserved for Pin 4 on the power connector.

Pins 3, 4, 11 and 12 (Digital inputs 2 to 5) have a voltage of 3.3 VDC when set to high in ACEmanager. A voltage on the pins of:

- 2.2 VDC to 30 VDC = logic 1
- 0 VDC to 1.3 VDC = logic 0

I/O X-Card Analog Voltage Input Pins

Pins 7, 8, 14 and 15 are the analog voltage sensing pins configured in ACEmanager. Analog inputs monitor voltage changes in small increments. This allows you to monitor equipment that reports status as an analog voltage. You can use volts as the units reported or you can use the ACEmanager I/O Configuration screen to convert voltage to the desired units of measurement. You can also use the Event Reporting feature in ACEmanager to configure reports to be sent when an analog threshold is crossed. For more information, refer to the ALEOS Software Configuration User Guide.

The pins have a maximum rating of 30 V, 200 μ A.

Table 2-8: I/O X-Card Analog Voltage Input Pins

Pins	Name	Specification	Parameter	Min	Typical	Max	Units
7 8 14 15	AIN[1...4]	Voltage range	VADC	0	—	30	V
		Input leakage current		—	—	200	μ A
		Input capacitance	CIN	—	30	—	pF
		Error		0	2.5	5	%

These pins detect inputs of 0–30 VDC across the pins to ground. When used with a sensor to transform values into voltages, the pins can monitor measurements like temperatures, pressures or the volume of liquid in a container. ACEmanager can transform these voltages into meaningful values. In ACEmanager, events reporting tells the gateway to perform an action when a specified voltage is detected.

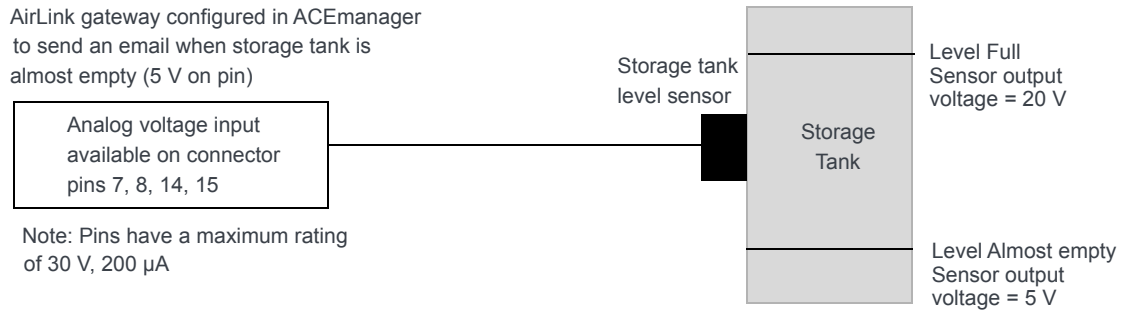

Figure 2-27: I/O X-Card Analog Voltage Input Operation

I/O X-Card RS-232 Port

Four pins on the high-density DB15 support a 4-wire RS-232 interface. The interface also supports features like AT, TCP PAD and UDP PAD.

Table 2-9: I/O X-Card RS-232 Port

Pins	Name	Specification	Parameter	Min	Typical	Max	Units
1 2	TXD CTS	Output low state voltage range	VOL	-5.0	-7.0	—	V
		Output high state voltage range	VOH	+5.0	+7.0	—	V
		Short circuit current	1 short	—	\pm 35	\pm 70	mA
		Leakage current	1 leak	—	\pm 0.1	\pm 10	μ A
5 6	RXD RTS	Input low state voltage range	VIL	-5.0	—	-20	V
		Input high state voltage range	VIH	+5.0	—	+20	V
		Input resistance	R in	3	5	7	k Ω

Note: There is no connection for RI, DCD, DTR or DSR. These are available on the DB-9 serial port. See [Serial Port](#) on page 36.

Dual Ethernet X-Card

This card adds two RJ-45 Ethernet ports to the gateway for a total of three. The two Ethernet ports on the X-Card are bridged with the gateway's main Ethernet port, automatically becoming part of the same subnet.

The main Ethernet port on the rear panel is a high performance Ethernet port with data rates up to 100 Mbps.

The Dual Ethernet X-Card provides additional Ethernet ports for applications requiring lower throughput (in the range of 8–9 Mbps, or less if both ports are being used).

For example, the Ethernet ports on the Dual Ethernet X-Card are ideal for applications that run on IP or other protocols that run on top of IP such as TCP and UDP.

Other suggested applications include:

- Modbus applications
- Low Resolution MMS (MultiMediaStreaming using mms://) applications
- Message Queuing Telemetry Transport (MQTT) applications
- Low Resolution Video surveillance applications

Configuring Dual Ethernet X-Card Ports

When your GX450 gateway has a Dual Ethernet X-Card installed, you can configure the additional Ethernet ports as Ethernet 2 and Ethernet 3 on the ACEmanager LAN > Ethernet screen. Information about the Ethernet ports appears on the Status > LAN and the Status > About screens. The LAN IP packets sent and received fields on the Status > LAN screen show the cumulative totals for all LAN interfaces.

>> 3: Configuring AirLink GX450 Gateways

This chapter shows you how to communicate with and configure the Sierra Wireless AirLink GX450 gateway.

Connection Ports

You can connect to the gateway's:

- USB port (Micro AB)
- Ethernet port (RJ-45)
- Serial port (9-pin RS-232)

USB Port

The USB port can be either a Virtual Ethernet port or a Virtual serial port.

Drivers must be installed on the PC for it to work in either mode. The drivers are available for download on Sierra Wireless' support web site:

source.sierrawireless.com/resources/airlink/software_downloads/airlink_usb_driver/

We recommend that you use a USB 2.0 cable connected directly to your computer for best throughput.

Configuring with ACEmanager

After the initial power up:

1. On the laptop connected to the gateway, open a web browser.
2. In the browser's address bar, enter **http://192.168.13.31:9191**

Note: It may take a minute or two for the gateway to respond after the first power up.

The ACEmanager login screen appears.

3. The default user name, user, is already entered. Enter the default password, **12345**. For devices with unique default passwords, enter the password printed on the label on the base of the unit.

Note: For system security, ensure that you change the default password as soon as possible.

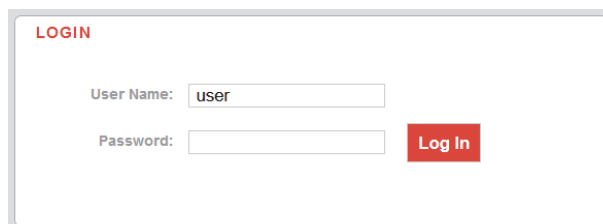

The screenshot shows a web browser window with a login form. At the top left, the word "LOGIN" is written in red. Below it, there are two input fields: "User Name:" followed by a text box containing the word "user", and "Password:" followed by an empty text box. To the right of the password field is a red button with the text "Log In" in white.

Figure 3-1: ACEmanager Login Screen

4. Click Log In.

The ACEmanager Status > Home page appears.

[-] General	
AT Active WAN IP Address	10.254.78.160
AT Network State	Network Ready
Network Interface	Cellular
AT Customer Device Name	LA44220088001001
Device Uptime	0 days, 0 hours, 9 minutes

Figure 3-2: ACEmanager Status > Home page¹

5. If the gateway does not automatically connect to the network:

- a. Check the Network State field. It should say “Network Ready”. If it says “No SIM or Unexpected SIM”, check that the correct SIM card is inserted. (See [Installing the SIM Card](#) on page 14.)
- b. Check the Signal Strength field on the Status > Cellular page. It should be greater than -100.
- c. Check the APN on the WAN/Cellular > Cellular > General page. If an error message appears in this field, contact your Mobile Network Operator. They may need to provide you with an APN to enter in the User Entered APN field.

1. The appearance of the page varies depending on the version of ALEOS installed on the gateway, the presence of X-Cards, and the type of network the gateway is connected to.

The screenshot displays the ACEmanager configuration interface for WAN/Cellular settings. The top navigation bar includes tabs for Status, WAN/Cellular, Wi-Fi, LAN, VPN, Security, Services, Location, Events Reporting, Serial, Applications, I/O, and Admin. The main content area is divided into sections: General, Cellular, Monitor, Ethernet, Static Configuration, Monitor, Reliable Static Route (RSR), Policy Routing, DMNR Configuration, and PNTM Configuration. The Cellular section is expanded to show the General sub-section, which includes fields for Network Credentials, APN in Use (highlighted with a red circle and containing 'isp.telus.com'), AT User Entered APN, AT 3G RX Diversity (set to 'Enable'), AT SIM PIN (with a red 'SIM PIN' button), and AT IP Address Preference (set to 'IPv4'). There are also expandable sections for Band Setting, Cellular Watchdog, Advanced, and APN Backup.

Figure 3-3: ACEmanager: WAN/Cellular

To configure the gateway using ACEmanager, refer to the ALEOS Software Configuration User Guide, available for download from source.sierrawireless.com.

After the GX450 gateway is connected and configured, you can save the configuration as a template to the configuration PC and then apply this template to subsequent GX450 gateways. For details, refer to the ALEOS Software Configuration User Guide.

Configuring with AirLink Management Service

AirLink Management Service (ALMS) is a cloud-based service that provides remote monitoring and configuration of multiple AirLink gateways.

To use ALMS, you must have an account. For more information, go to www.sierrawireless.com/ALMS.

To access AirLink Management Service:

1. Connect a laptop to the GX450 gateway with an Ethernet cable.
2. Log in to ACEmanager.
3. Go to the Services tab and ensure that ALMS is enabled and the server URL is <http://na.m2mop.net/msci/com>. If this is not the case, enter the correct URL, click Apply and then click Reboot.
4. In your browser, go to <http://airvantage.net> and log in.
5. Follow the instructions in the online ALMS documentation to register your gateway.

Configuring with AMM

AirLink Mobility Manager (AMM) is a Network Management solution that provides a consolidated view of the entire vehicle fleet and enables simplified management, control and monitoring of connected AirLink routers. AMM is a licensed, unified software platform deployed in the enterprise data center. It enables:

- Mobile network and asset management
- Over-the-air registration, configuration and software updates
- Consolidated network view of an entire fleet, in-field applications and mobile assets, using a virtual dashboard to monitor, report, manage, and troubleshoot all mobile resources as required.

If you require a network management solution deployed in your data center, contact your Sierra Wireless Partner for a demonstration of AMM capabilities.

Configuring with AT Commands

You can also configure GX450 gateways using AT commands over the RS-232 serial port or the USB port (configured as a virtual serial port). All the commands are listed in the ALEOS Software Configuration User Guide.

In ACEmanager, mouse over a red AT to the left of a listing to see a popup showing the AT command for that item.

- Most AT commands are prefaced with AT. Exceptions are noted in the ALEOS Software Configuration User Guide.
- The acceptable format and parameters are listed with each command in the ALEOS Software Configuration User Guide.
- If you enter a recognized AT command, the GX450 gateway responds with “OK.” If the command is wrong, the gateway responds with “ERROR” or “Unsupported.”

Reset to Factory Default Settings

To reset the gateway to the factory default settings, either:

- Press and hold the Reset button until all the LEDs turn red (about 7–10 seconds). See [Front Panel](#) on page 8.

Or

- In ACEmanager, go to Admin > Advanced and click the Reset to Factory Default button. For details, refer to the ALEOS Software Configuration User Guide.

The gateway reboots. Once the reboot is complete and the LEDs resume their normal operating behavior, the reset is complete.

Recovery Mode

If the gateway fails to boot properly, it automatically enters recovery mode, or, if the gateway is unresponsive to ACEmanager input and AT commands, you can manually put the gateway into Recovery mode.

Recovery mode enables you to update the ALEOS software and return the gateway to working order. (For details, refer to the ALEOS Software Configuration User Guide—Gateway Configuration chapter.)

To enter Recovery mode manually:

- On the gateway, press the Reset button for more than 20 seconds. (Release the button when all the LEDs are solid amber.)

To recover the gateway:

- Update ALEOS using the Recovery mode interface. Once the new ALEOS version is successfully uploaded and installed, the gateway reboots and exits recovery mode. When the process is complete, the ACEmanager login screen appears.

Note: After the recovery, you need to reload the radio module firmware store and templates.

To exit Recovery mode, if it has been inadvertently entered, do one of the following:

- Press the reset button on the gateway to reboot it.
- Click the Reboot button on the Recovery screen.
- Wait 10 minutes. If no action is taken within 10 minutes of the device entering Recovery mode (for example, if the Recovery screen has not been loaded by the web browser), it automatically reboots and exits Recovery mode.

For more information, refer to the ALEOS Software Configuration User Guide (Gateway Configuration chapter).

>> 4: AirLink GX450 Specifications

RF Specifications

Radio Frequency Bands

Table 4-1: GX450 North America—MC7354

Radio Technology	SKU				Band	Frequency
	Generic	Verizon Wireless	AT&T	Sprint		
LTE	✓		✓		Band 2 (1900 MHz)	Tx: 1850–1910 MHz Rx: 1930–1990 MHz
	✓	✓	✓		Band 4 (AWS) (1700/2100 MHz)	Tx: 1710–1755 MHz Rx: 2110–2155 MHz
	✓		✓		Band 5 (850 MHz)	Tx: 824–849 MHz Rx: 869–894 MHz
	✓	✓			Band 13 (700 MHz)	Tx: 777–787 MHz Rx: 746–756 MHz
	✓		✓		Band 17 (700 MHz)	Tx: 704–716 MHz Rx: 734–746 MHz
	✓			✓	Band 25 (1900 MHz Block G)	Tx: 1850–1915 MHz Rx: 1930–1995 MHz
CDMA/ EV-DO	✓	✓		✓	BC0 (Cellular 800 MHz)	Tx: 824–849 MHz Rx: 869–894 MHz
	✓	✓		✓	BC1 (PCS 1900 MHz)	Tx: 1850–1910 MHz Rx: 1930–1990 MHz
	✓			✓	BC10 (Secondary 800 MHz)	Tx: 817–824 MHz Rx: 861–869 MHz

Table 4-1: GX450 North America—MC7354 (Continued)

Radio Technology	SKU				Band	Frequency
	Generic	Verizon Wireless	AT&T	Sprint		
HSPA	✓	✓	✓	✓	Band 1 (2100 MHz)	Tx: 1920–1980 MHz Rx: 2110–2170 MHz
	✓	✓	✓	✓	Band 2 (1900 MHz)	Tx: 1850–1910 MHz Rx: 1930–1990 MHz
	✓				Band 4 (AWS 1700/2100 MHz)	Tx: 1710–1755 MHz Rx: 2110–2155 MHz
	✓	✓	✓	✓	Band 5 (850 MHz)	Tx: 824–849 MHz Rx: 869–894 MHz
	✓	✓	✓	✓	Band 8 (900 MHz)	Tx: 880–915 MHz Rx: 925–960 MHz
EDGE	✓	✓	✓	✓	GSM 850 (850 MHz)	Tx: 824–849 MHz Rx: 869–894 MHz
	✓	✓	✓	✓	GSM 900 (900 MHz)	Tx: 880–915 MHz Rx: 925–960 MHz
	✓	✓	✓	✓	DCS 1800 (1800 MHz)	Tx: 1710–1785 MHz Rx: 1805–1880 MHz
	✓	✓	✓	✓	PCS1900 (1900 MHz)	Tx: 1850–1910 MHz Rx: 1930–1990 MHz

Table 4-2: GX450 International—MC7304

Radio Technology	SKU		Band	Frequency
	Generic	Telstra		
LTE	✓	✓	Band 1 (2100 MHz)	Tx: 1920–1980 MHz Rx: 2110–2170 MHz
	✓	✓	Band 3 (1800 MHz)	Tx: 1710–1785 MHz Rx: 1805–1880 MHz
	✓	✓	Band 7 (2600 MHz)	Tx: 2500–2570 MHz Rx: 2620–2690 MHz
	✓	✓	Band 8 (900 MHz)	Tx: 800–915 MHz Rx: 925–960 MHz
	✓	✓	Band 20 (800 MHz)	Tx: 832–862 MHz Rx: 791–821 MHz

Table 4-2: GX450 International—MC7304 (Continued)

Radio Technology	SKU		Band	Frequency
	Generic	Telstra		
HSPA	✓	✓	Band 1 (2100 MHz)	Tx: 1920–1980 MHz Rx: 2110–2170 MHz
	✓	✓	Band 2 (1900 MHz)	Tx: 1850–1910 MHz Rx: 1930–1990 MHz
	✓	✓	Band 5 (850 MHz)	Tx: 824–849 MHz Rx: 869–894 MHz
	✓	✓	Band 8 (900 MHz)	Tx: 880–915 MHz Rx: 925–960 MHz
EDGE	✓	✓	GSM 850 (850 MHz)	Tx: 824–849 MHz Rx: 869–894 MHz
	✓	✓	GSM 900 (900 MHz)	Tx: 880–915 MHz Rx: 925–960 MHz
	✓	✓	DCS 1800 (1800 MHz)	Tx: 1710–1785 MHz Rx: 1805–1880 MHz
	✓	✓	PCS1900 (1900 MHz)	Tx: 1850–1910 MHz Rx: 1930–1990 MHz

Radio Module Conducted Transmit Power

The following tables provide radio module conducted transmit power specifications. The radio module type is printed on the label on the bottom of the gateway and is available in ACEmanager (Status > About).

Table 4-3: GX450 North America—MC7354^a Conducted Transmit Power

Band	Conducted Tx Power (dBm)	Notes
LTE		
Band 1 Band 4 Band 13 Band 17 Band 25	+23±1	

Table 4-3: GX450 North America—MC7354^a Conducted Transmit Power

Band	Conducted Tx Power (dBm)	Notes
UMTS		
Band 1 (IMT 2100 12.2 kbps) Band 2 (UMTS 1900 12.2 kbps) Band 4 (AWS 1700/2100 12.2 kbps) Band 5 (UMTS 850 12.2 kbps) Band 8 (UMTS 900 12.2 kbps)	+23±1	Connectorized (Class 3)
GSM/EDGE		
GSM 850 CS GSM 900 CS	+32±1	GMSK mode, connectorized (Class 4)
	+27±1	8 PSK mode, connectorized (Class E2)
DCS 1800 CS PCS 1900 CS	+29±1	GMSK mode, connectorized (Class 4)
	+26±1	8 PSK mode, connectorized (Class E2)
CDMA		
Band Class 0 (Cellular)	+24+0.5/-1	
Band Class 1 (PCS)		
Band Class 10 (Cellular)		

a. You can view the Radio Module Type in ACEmanager (Status > About).

Table 4-4: GX450 International—MC7304^a Conducted Transmit Power

Band	Conducted Tx Power (dBm)	Notes
LTE		
Band 1 Band 3 Band 8 Band 20	+23±1	
Band 7	+22±1	

Table 4-4: GX450 International—MC7304^a Conducted Transmit Power (Continued)

Band	Conducted Tx Power (dBm)	Notes
UMTS		
Band 1 (IMT 2100 12.2 kbps) Band 2 (UMTS 1900 12.2 kbps) Band 5 (UMTS 850 12.2 kbps) Band 6 (UMTS 800 12.2 kbps) Band 8 (UMTS 900 12.2 kbps)	+23±1	Connectorized (Class 3)
GSM / EDGE		
GSM 850 CS GSM 900 CS	+32±1	GMSK mode, connectorized (Class 4)
	+27±1	8 PSK mode, connectorized (Class E2)
DCS 1800 CS PCS 1900 CS	+29±1	GMSK mode, connectorized (Class 4)
	+26±1	8 PSK mode, connectorized (Class E2)

a. You can view the Radio Module Type in ACEmanager (Status > About).

Host Interfaces

- 10/100 Base-T RJ-45 Ethernet
- RS-232 Serial port
- USB V2.0 Micro-AB connector
- 3 SMA antenna connectors (RF, GPS, Rx Diversity)
- Support for active antenna

GPS Technology

- Protocols: NMEA 0183 V3.0, TAIP, RAP
- Acquisition time: 2 sec hot start
- Accuracy: < 2 m (50%), < 5 m (90%)
- Tracking sensitivity: -161 dBm
- Datum: WGS84

Protocols

- Network: TCP/IP, UDP/IP, DNS
- Routing: NAT, Host Port Routing, DHCP, PPPoE, VLAN, VRRP
- Application: SMS, Telnet/SSH, SMTP, SNMP, SNTP
- Serial: TCP/UDP PAD Mode, Modbus (ASCII, RTU, Variable), PPP

Events Reporting

- Event Types:
 - Digital input
 - GPS/AVL
 - Network parameters
 - Data usage
 - Timer
 - Power
 - Gateway temperature
- Report/Action Types:
 - SMS
 - Email
 - SNMP trap
 - Relay output
 - GPS RAP report
 - Events protocol message to server

VPN/Security

- IPsec, SSL, and GRE VPN client
- Up to 5 VPN tunnels
- IKE encryption
- Port forwarding and DMZ
- Port filtering
- Trusted IP
- MAC address filtering

Gateway Management

- AirLink Management Service cloud-based gateway management application
For more information, go to www.sierrawireless.com/ALMS.
- ACEManager web-based gateway configuration software
For more information, refer to the ALEOS Software Configuration User Guide.
- AT Commands
For more information, refer to the ALEOS Software Configuration User Guide.

ALEOS Application Framework

- Lua language coding platform
- Remote application management
- Eclipse-based IDE
- Integrated real-time debugging

Input/Output

- Configurable I/O on power connector
- Input ON voltage: 3.3 VDC to 30 VDC
- Input OFF voltage: 0 VDC to 1.2 VDC
- Output maximum switching capability 200 mA @ 30 VDC

Power Consumption

Table 4-5: GX Series gateway power consumption (without X-Card)

AirLink GX Series Gateways (no X-Card installed)	
Maximum current draw at 12 V	1 A
Typical current draw at 12 V	0.45 A
Low Power Mode current draw at 12 V	50 mA

Additional Power Consumption with X-Cards Installed

Table 4-6 outlines the increase in power consumption if you have an X-Card installed in the GX Series gateway.

Table 4-6: Additional power consumption with X-Card installed^a

	Dual Ethernet X-Card	Wi-Fi X-Card	Serial I/O X-Card
Change Typical	148 mA	110 mA	19 mA
Change Maximum	200 mA	155 mA	30 mA

a. Values are averaged over 2 minutes at +12 V at room temperature.

Environmental Specifications

- Operating temperature: -30°C to +70°C (-22°F to +158°F)^{1 2}
- Storage temperature: -40°C to +85°C (-40°F to +185°F)
- Humidity: Maximum 95% RH @ 60°C (140°F)

Table 4-7: Environmental Test Specifications

Category	Operational / Non-operational	Reference
Temperature	Operational	MIL-STD-810G, 501.5, 502.5
	Non-operational	MIL-STD-810G, 501.5, 502.5
Humidity	Operational	MIL-STD-810G, 507.5
Drop	Non-operational	ISTA 2A 2001, test categories 1, 4, 5, and 6 or equivalent
Vibration	Operational	MIL-STD-810G, test method 514.6, 527
Shock	Operational	MIL-STD-810G, test method 516.6
Thermal Shock	—	MIL-STD-810G, test method 503.5
IP Rating	—	IP64

Wi-Fi X-Card

- IEEE 802.11b/g/n
- Both access point and client capability
- When used as an access point, up to 8 clients can connect simultaneously
- When used as a client, can connect to one of up to 10 configured access points.
- Security:
 - WEP 64-bit and 128-bit encryption with H/W TKIP processing
 - WPA/WPA2 (Wi-Fi Protected Access)
 - AES-CCMP hardware implementation as part of 802.11i security
- SMA antenna connector
- Frequency range: 2.4 GHz

Number of channels:

- 802.11b:
 - USA, Canada, and Taiwan—11
 - Most European countries—13
 - France—4
 - Japan—14
- 802.11g:
 - USA, Canada, and Taiwan—11
 - Most European countries—13
 - Japan—13

1. The AC adapter has a narrower range of operating temperatures. See AC Adapter [Accessories](#) on page 64.
2. UL Listed for use in ambient temperatures not exceeding 60°C.

- 802.11n:
 - HT20: Channel 1~14 (2412~2484)
- Output power—WAN:
 - 802.11b: typical 16 dBm \pm 1.5 dBm
 - 802.11g: typical 14 dBm \pm 1.5 dBm
 - 802.11n (HT20 and HT40): typical 13 dBm \pm 1.5 dBm
- Receive sensitivity (WAN):
 - 802.11b: typical -86 dBm at 11 Mbps
 - 802.11g: typical -70 dBm at 54 Mbps
 - 802.11n: typical -69 dBm at HT20 MCS7
 - 802.11n: typical -66 dBm at HT40 MCS7
- Data Rates
 - 802.11b: 1, 2, 5.5, 11 Mbps
 - 802.11g: 6, 9, 12, 18, 24, 36, 48, 54 Mbps
 - 802.11n: up to 65 Mbps
- Maximum Operating Range
 - Open space: ~100–125 m
 - Indoors: ~50 m
- RF Output Power

Wi-Fi Network	Typical RF Transmit Power
802.11b	16dBm \pm 1.5dBm
802.11g	14dBm \pm 1.5dBm
802.11n(HT20)	13dBm \pm 1.5dBm
802.11n(HT40)	13dBm \pm 1.5dBm

I/O X-Card

- 4 configurable digital I/O
- 4 analog inputs
 - Range of 0 to 30V
 - 10-bit resolution
- RS-232 Serial port

Dual Ethernet X-Card

- 2 configurable RJ-45 Ethernet ports
- LEDs
 - Link: 100Base-T=green/10Base-T= off.
 - Activity: amber
- Physical Layer Support: 10Base-T, 100Base-T
- Auto Negotiation: 10Base-T, 100Base-T, Half and Full duplex
- Standards: IEEE 802.3 / 802.3u
- Auto Crossover: HP Auto MDI-X

Certifications

Certification	GX450
FCC	✓
IC	✓
PTCRB	✓
CB Scheme	✓
Class 1 Div 2	✓
RCM A-Tick	✓
CE	✓
RED	✓
RoHS	✓
REACH	✓
WEEE	✓
UL 60950	✓
E-Mark (2009/19/EC), ISO 7637-2	✓
GCF	✓

Power

- Voltage range: 9–36 VDC

Construction Materials

The GX450 case is die cast using aluminum alloy A380, which is powder coated. The cover is a fire-retardant plastic.

Reliability

The GX450 gateway has an MTBF of approximately 9.5 years.

Mechanical Specifications

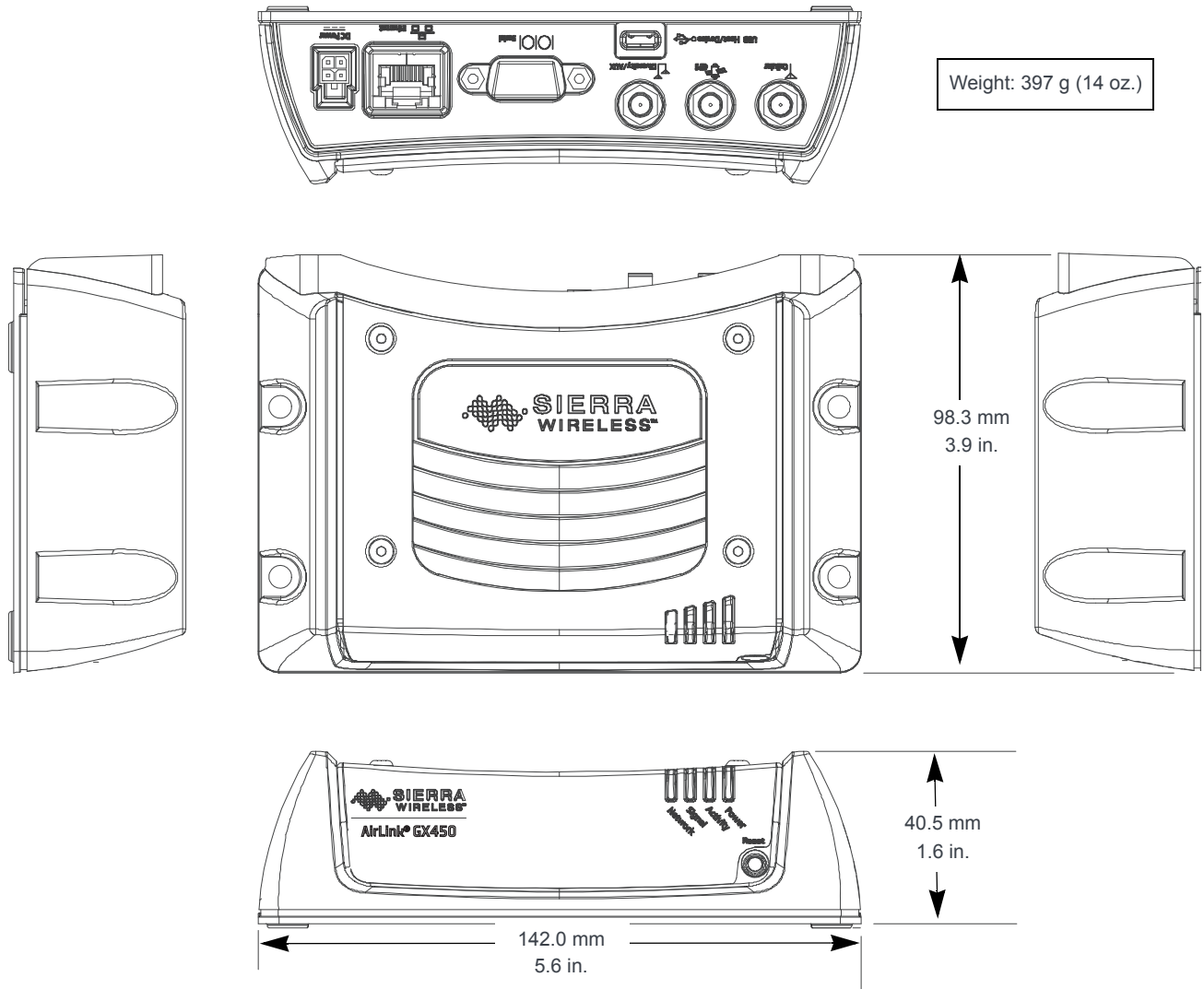

Figure 4-1: AirLink GX450 Mechanical Specifications (Standard Gateway Shown)

The locking power connector housing and the internal wire connector that fits it are:

- Tyco micro Mate-N-Lok double row connector housing receptor
p/n 794617-4
- Tyco female 3 mm Centerline, 250 V, 5 A max. crimp terminal
p/n 794606-1

>> 5: Regulatory Information

Federal Communications Commission Notice (FCC United States)

This equipment has been tested and found to comply with the limits for a Class A digital device, pursuant to part 15 of the FCC Rules. These limits are designed to provide reasonable protection against harmful interference when the equipment is operated in a commercial environment.

This equipment generates, uses, and can radiate radio frequency energy and, if not installed and used in accordance with the instruction manual, may cause harmful interference to radio communications. Operation of this equipment in a residential area is likely to cause harmful interference in which case the user will be required to correct the interference at his own expense.

Warning: *Changes or modifications to this gateway not expressly approved by Sierra Wireless could void the user's authority to operate this equipment.*

Notice for Canadian Users

This Class A digital apparatus complies with ICES-003.

Cet appareil numérique de la classe A est conforme à la norme NMB-003 du Canada.

Industry Canada Notice

This Class A device complies with RSS-210 of the Industry Canada rules. Operation is subject to the following two conditions:

1. This device may not cause harmful interference, and
2. This device must accept any interference received, including interference that may cause undesired operation of the device.

Avis d'Industrie Canada

Cet appareillage numérique de la Classe A est conforme aux normes RSS-210 du Canada. L'utilisation de ce dispositif est autorisée seulement aux conditions suivantes :

1. Il ne doit pas produire de brouillage et
2. Il doit accepter tout brouillage radioélectrique reçu, même si ce brouillage est susceptible de compromettre le fonctionnement du dispositif.

Important Information for North American Users on Radiation Exposure

This equipment complies with FCC/IC radiation exposure limits set forth for an uncontrolled environment. This equipment should be installed and operated with a minimum distance of 20 cm between the radiator and the user's body.

Warning: *This gateway is only to be installed by qualified personnel.*

To comply with FCC/IC regulations limiting both maximum RF output power and human exposure to RF radiation, maximum antenna gain must not exceed the values given in the tables in [Maximum Antenna Gain \(Gain D'antenne Maximal\)](#) on page 62.

Warning: *A minimum separation distance of 20 cm must be maintained between the antenna(s) used for this transmitter and all personnel.*

Informations Importantes Pour les Utilisateurs Nord-Américains sur L'exposition aux Radiations

Ce matériel est conforme aux limites établies par FCC/IC en matière d'exposition aux radiofréquences dans un environnement non contrôlé. Ce matériel doit être installé et utilisé à une distance d'au moins 20 cm entre l'antenne et le corps de l'utilisateur.

Avertissement : *Ce produit est uniquement être installé par du personnel qualifié.*

Pour se conformer aux normes FCC/IC réglementation limitée à la fois la puissance maximale de sortie RF et l'exposition humaine aux rayonnements RF, gain d'antenne maximal ne doit pas dépasser les valeurs indiquées dans les tableaux de la section de gain d'antenne maximal.

Avertissement : *Une distance minimale de 20 cm doit être maintenue entre l'antenne (s) utilisées pour cet émetteur et l'ensemble du personnel.*

Maximum Antenna Gain (Gain D'antenne Maximal)

The Wi-Fi X-Card may transmit simultaneously with other collocated radio transmitters within a host device, as permitted by FCC/IC multi-transmitter product procedures. The antenna gain must not exceed the limits and configurations shown in the following tables.

Device	Frequency Band	FCC ID/IC Number	
		Standalone	Collocated
		N7NMC7355 2417C-MC7355	
GX450	Cellular Band	6.5 dBi	3.0 dBi
	PCS Band	3.0 dBi	3.0 dBi
	Band 4	6.0 dBi	6.0 dBi
	Band 13	9.0 dBi	6.0 dBi
	Band 17	9.0 dBi	6.0 dBi
	Band 25	3.0 dBi	3.0 dBi
Collocated Transmitter (Wi-Fi X-Card Option)	WLAN (2.4 GHz)	N/A	2.0 dBi

EU

Sierra Wireless hereby declares the AirLink GX450 conforms to all the essential requirements of Directive 2014/53/EU.

This product displays the CE mark.



The AirLink GX450 is compliant with the RF exposure requirements at 20 cm separation distance specified in EN 62311:2008 and 1999/519/EC for mobile exposure conditions, provided the maximum antenna gain does not exceed the limits given in the table below.

Model	Frequency Band	Maximum Antenna Gain (dBi)
GX450 (MC7304 module)	WWAN	5.00
Optional Wi-Fi X-Card	WLAN (2.4 GHz)	2.00

Note: The Wi-Fi X-Card only works in the 2.4 GHz band.

Warning: *These products are only to be installed by qualified personnel.*

Warning: *Changes or modifications to this gateway not expressly approved by Sierra Wireless could void the user's authority to operate this equipment.*

Warning: *A minimum separation distance of 20 cm must be maintained between the antenna(s) used for this transmitter and all personnel.*

Declaration of Conformity

The Declaration of Conformity made under Directive 2014/53/EU is available for viewing at: source.sierrawireless.com.

WEEE Notice



If you purchased your AirLink GX450 gateway in Europe, please return it to your dealer or supplier at the end of its life. WEEE products may be recognized by the wheeled bin label on the product label.

Notice for Brazilian Users

Este equipamento opera em caráter secundário, isto é, não tem direito a proteção contra interferência prejudicial, mesmo de estações do mesmo tipo, e não pode causar interferência a sistemas operando em caráter primário.

>> A: Accessories

DC Power Cable (Black Connector)

Table A-1: DC Power Cable

DC Power Cable	
Part Number	2000522
Product Release	2016

Components:

- ① 1 UL2464 20 AWG × 4 core cable
- ② 4 Molex female crimp terminals /AWG 20-24, 250 V, 4 A max, phosphor bronze tin-plated (part number 43030-0001)
- ③ 1 Molex male 2×2P Ph: 3.0 mm housing, 250 V, 5 A max, PA65 black UL94V-O (part number 43025-0408)

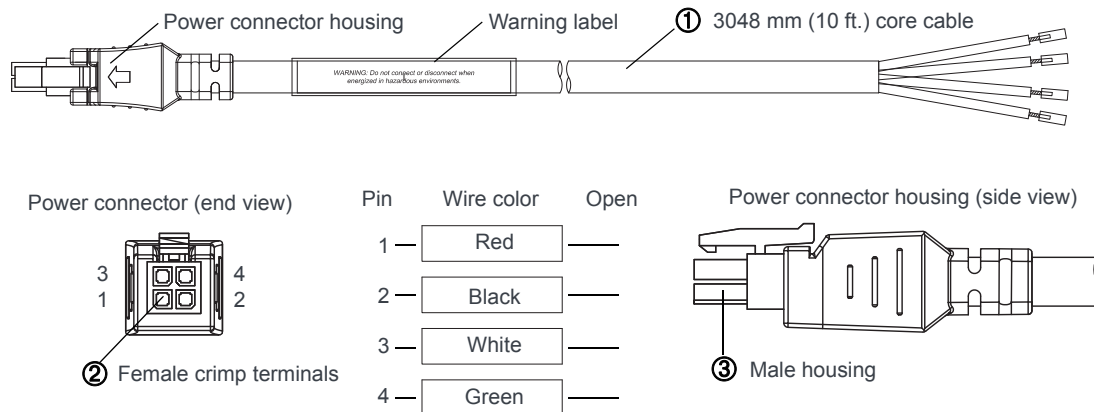

Figure A-1: DC Cable Specifications

AC Power Adapter (Black Connector)

AC Power Adapter	
Part Number	2000579
Product Release Date	2016

AC Power Adapter Input

Table A-2: Input Specifications

	Minimum	Typical	Maximum
Input			
Input Voltage	90 VAC	100–240 VAC	264 VAC
Input Frequency	47 Hz	50/60 Hz	63 Hz
<i>Note: Input voltage range is 90 VAC to 264 VAC. Maximum input current is 500 mA at 100–240 VAC. Inrush current will not exceed 75 A at 100–240 VAC input and maximum load from a cold start at 25°C.</i>			

AC Power Adapter Output

Table A-3: AC Power Adapter Output Specifications

	Minimum	Typical	Maximum	Test conditions	
Output Voltage	—	11.4 VDC	12.0 VDC	12.6 VDC	0 ~ 1.5 A loading

AC Power Adapter Environmental Specifications

Table A-4: AC Power Adapter Environmental Specifications

Operating	
Operating Temperature	0°C ~ 40°C (operates normally)
Relative Humidity	10% ~ 90%
Altitude	Sea level to 2,000 meters
Vibration	1.0 mm, 10–55 Hz, 15 minutes per cycle for each axis (X, Y, Z)
Non-operating	
Storage Temperature	-30°C ~ 70°C
Relative Humidity	10% ~ 90%
Vibration and Shock	MIL-STD-810D, method 514

AC Power Adapter Reliability and Quality Control

AC Power Adapter MTBF

When the power supply is operating within the limits of this specification, the MTBF is at least 200,000 hours at 25°C (MIL-HDBK-217F).

Note: For router MTBF, see [Reliability](#) on page 58.

AC Power Adapter Safety Standards

The power supply is certified with the following international regulatory standards:

Regulatory Agency	Country or Region	Certified	Standard
UL	USA	Approved	UL60950-1
GS	Europe	Approved	EN60950-1
CE	Europe	Approved	EN60950-1
SAA	Australia	Approved	AS/NZS 60950
CCC	China	Approved	GB4943
CUL	Canada	Approved	CSA C22.2 NO.60950-1

AC Power Adapter EMC Standards

The power supply meets the radiated and conducted emission requirements for EN55022, FCC Part 15, Class B, GB9254.

Hazardous Substances

- EU Directive 2011/65/EU “RoHS”
- EU Directive 2012/19/EU “WEEE”
- REACH

Energy Efficiency

The AC adapter complies with International Efficiency Levels, as shown in [Table A-5](#).

Table A-5: AC Adapter Energy Efficiency

Supplied Input	No-load Power Consumption	Average Active Mode Efficiency	International Efficiency Level
115 VAC, 60 Hz	Less than 0.1 W	Greater than 85%	VI
230 VAC, 50 Hz	Less than 0.3 W	Greater than 80.4%	V

>> Index

A

- AC Power Adapter, 64
- Accessories, 11
- ACEmanager, 11
- AirLink Management Service (ALMS), 11
- ALEOS
 - Default user name and password, 44
 - Description of, 10
 - X-Card installed, 37
- ALEOS Application Framework, 54
- AMM, 47
- Analog input voltage sensing
 - On power connector, 35
 - On X-Card, 38
- Antenna
 - Auxiliary receive port, 9
 - Connection of, 29
 - Diversity/AUX, 9
 - GPS connector, 9
 - Installation, 27
 - Maximum gain, 8, 62
 - Receive and transmit port, 8
 - Safe mounting, 25
 - Separation, 27
- AUX/Diversity antenna connector, 9

C

- Cables
 - Connecting to gateway, 29
 - Power and data, connection of, 29
- Certifications, 58
- Communication
 - Command line prompt, using, 30
 - Connection, 29
 - Ethernet connector, 9
 - TCP PAD, 9
 - UDP PAD, 9
 - Virtual Ethernet/serial port via USB, 9
 - Wi-Fi X-Card, 38
 - X-Card RS-232 port, 38
- Configuring with
 - ACEmanager, 44
 - AirLink Management Service, 46
 - AT commands, 47
- Connecting to gateways and power, 29
- Construction materials, 58

D

- DC power cable, connecting, 32, 33
- Default settings for gateway, reset to, 8
- Description, gateway, 8
- Digital I/O pins on X-Card, 38
- Diversity/AUX Antenna Connector, 9
- Dual Ethernet X-Card, 10

E

- Environmental specifications, 56

- Ethernet
 - Computer connection and log in, 44
 - Connector, 9
 - Virtual Ethernet/serial port, 44
- EU, 62
- Events reporting, 54
- Expansion Card, 37

F

- FCC, 60
- Front panel, 8

G

- Gateway
 - Description, 8
 - Front panel, 8
 - Installing, 13
 - Rear panel, 8
 - Tools and material, 13
- GPS
 - Antenna connector, 9
 - Antenna, mounting, 29
 - Technology supported, 53

H

- Host interfaces, 53

I

- I/O X-Card, 10
- Industry Canada, 60
- Input/Output X-Card, 38
- installation, 13
- Installing SIM card, 14
- IP address, obtaining with command line prompt, 30

L

- LED
 - also see specific LED, 8
 - Description, 30
 - Ethernet, 32

M

- Measuring external voltages, 35
- Mechanical specifications, 59
- Mounting
 - General instructions, 25
 - GPS antenna, 29
 - In vehicle, 25
- MTBF
 - AD adapter, 66
 - Gateway, 58

O

Output/Input X-Card, 38

P

Pinging gateway with command line prompt, 30

Power consumption, 55

Power, connector, measuring external voltages, 35

Protocols, 53

R

Radiation exposure, 61

Radio frequency bands supported, 49

Rear panel, 8

Receive port, backup, 9

Regulatory information, 60

Regulatory specifications, 66

Reliability, 58

Reset button, 8

RS-232 port

On rear panel, 9

On X-Card, 38

S

Safety and Hazards, 2

Serial port

RS-232, 9

Virtual serial port, 44

SIM card, installing, 14

Specifications, 49

Standards, regulatory, 66

T

TCP PAD, 9

U

UDP PAD, 9

USB port

On front panel, 9

Uses of, installing drivers for, 44

V

Vehicle

Antenna, safe mounting, 25

Mounting, 26

Virtual Ethernet port, 9

Voltage

Analog voltage sensing pins on X-Card, 38

Monitoring battery or power input, 35

Range, 58

VPN/Security, 54

W

Warranty, 12

Wi-Fi X-Card, 38

X

X-Card, 10, 37

Analog voltage input pins, 41

Description, 10

Digital I/O, analog voltage sensing, pins, 38

Dual Ethernet, specifications, 57

I/O specifications, 57

Installed indicator in ALEOS, 37

Wi-Fi, 38

Wi-Fi specifications, 56