

ANTENNAS | EPNT-4 SERIES

X-POLARISED, OMNI-DIRECTIONAL, 5G/LTE & WI-FI CPE

617 – 4200 MHz, 3 dBi; 2400 – 2500 MHz & 5000 – 7200 MHz, 2.2 dBi



617 – 960 MHz 1427 – 1517 MHz 1710 – 2700 MHz 3400 – 4200 MHz	LTE: 3 dBi Wi-Fi: 2.2 dBi	Increase X Mb/s	Omnidirectional	5G	4G LTE	Urban
CBRS Band	4x4 MIMO	2.4 – 2.5 GHz 5.0 – 7.2 GHz	GPS Included	IP 67	-40°C to +80°C	Commercial & Industrial

APPLICATION AREAS



- Wideband 5G/LTE antennas up to 4x4 MIMO
- Backwards compatible with 2G/3G/4G technologies
- 2x2 MIMO Wi-Fi antennas for 2.4 GHz and 5 to 7.2 GHz
- Available router size of up to 140 x 120 x 50 mm³
- Weather/dust and vandal resistant enclosure (IP67)

Product Overview

The EPNT-4 is Poynting's newly added omni-directional, customer-premises equipment (CPE). The EPNT-4 offers a variety of antennas in one package, such as 4x4 5G/LTE MIMO, 2x2 Wi-Fi MIMO, as well as an additional GPS antenna. The cellular 5G/LTE antennas are wideband and operate from 617 to 4200 MHz, covering the major 5G/LTE bands with excellent gain across all frequencies, enhancing the 5G performance features, such as multi carrier aggregation (CA) for communication. While the Wi-Fi antennas offer dual band operation and cover the 2.4 GHz and 5 to 7.2 GHz Wi-Fi bands with a peak gain of 2.2 dBi. In addition, the antenna elements within the enclosure are cross-polarised, further improving the overall performance of the antenna. The combination of our cellular and Wi-Fi antennas, with a router will deliver a CPE with exceptional performance along with increased data throughput.

The EPNT-4 is also fully saltwater protected, so that it can be used in highly corrosive environments, including chemical and toxic environments, thanks to the UV stable ASA radome material. The enclosure also offers a robust mechanical design to withstand adverse weather conditions, making the EPNT-4 vandal and weatherproof with an IP67 & IK10 rating.

Features

- Wideband cellular coverage from 617 to 4200 MHz, with up to 4x4 MIMO
- 2x2 MIMO dual-band Wi-Fi at 2.4 & 5 to 7.2 GHz
- Cleverly designed decorrelated antennas give superior MIMO performance in both cellular and Wi-Fi bands
- Includes high-performance GPS/GLONASS antenna
- Precise mechanical design provides ruggedness, water, and dust resistance (IP67)
- Wall, pole, and surface mountable

Application Areas

- Industrial factory automation, robotic machinery and other M2M systems telemetry
- Farming & agricultural automation such as M2M & IoT
- Broadband cellular to Wi-Fi distribution for marine / boats (inland and near coastal vessels)
- Outdoor antenna for Fixed Wireless Access (FWA)
- Consumer 5G/LTE internet connectivity
- Industrial and commercial 5G/LTE deployment



Frequency Bands

The EPNT-4 is a CPE antenna that works from | 617 – 960 MHz | 1427 – 1517 MHz | 1710 – 2700 MHz | 3400 – 4200 MHz | and the following Wi-Fi frequency bands | 2400 – 2500 MHz | and | 5000 – 7200 MHz |

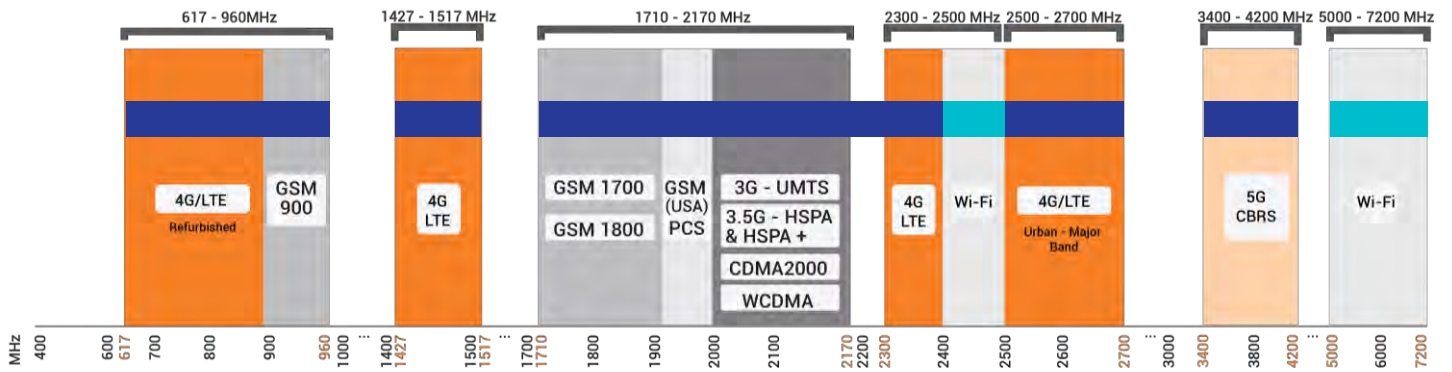

Indicates the LTE bands on which EPNT-4 works

Indicates the WI-FI bands on which EPNT-4 works

Antenna Derivatives

Product Order Code (SKU)	A-EPNT-0004-V1-15	A-EPNT-0004-V1-17
Ports	1 & 2 – LTE 3 & 4 - Wi-Fi 5 – GPS	1, 2, 3 & 4 – LTE 5 & 6 - Wi-Fi 7 - GPS
SISO / MIMO	2x2 MIMO – LTE 2x2 MIMO – Wi-Fi	4x4 MIMO – LTE 2x2 MIMO – Wi-Fi
Coax Cable Type	RTK-031 – LTE, Wi-Fi & GPS	RTK-031 – LTE, Wi-Fi & GPS
Coax Cable Length	150 mm - LTE, Wi-Fi & GPS	150 mm - LTE, Wi-Fi & GPS
Connector Type	RA SMA* (M) - LTE, & GPS RA RPSMA* (M)- Wi-Fi	RA SMA* (M) – LTE & GPS RA RPSMA* (M)- Wi-Fi
Weight	1.175 kg	1.19 kg
Packaged Weight	2.19 kg	2.21 kg
EAN	6009710924853	6009710924877

*RA SMA: Right Angle/90° SMA

*RA RPSMA: Right Angle/90° Reverse Polarity SMA

*The coax cables & connectors are factory mounted to the antenna

Electrical Specifications - Cellular

Frequency Bands:	617 – 960 MHz 1427 – 1517 MHz 1710 – 2700 MHz 3400 – 4200 MHz
Gain (Max):	1 dBi @ 617 – 960 MHz 2 dBi @ 1427 – 1517 MHz 3 dBi @ 1710 – 2700 MHz 0 dBi @ 3400 – 4200 MHz
VSWR:	<3:1
Feed Power Handling:	10 W
Input Impedance:	50 Ohm (nominal)
Polarisation:	Cell 1: ±45° Cross Polarised Cell 2: ±45° Cross Polarised
Path to Ground:	Yes

Electrical Specifications - Wi-Fi

Frequency:	2400 - 2500 MHz 5000 – 7200 MHz
Gain (Max):	2.2 dBi @ 2400 - 2500 MHz 2.2 dBi @ 5000 - 7200 MHz
VSWR:	<2.5:1 over 90% of the band
Feed Power Handling:	10 W
Nominal Input Impedance:	50 Ohm (nominal)
Polarisation:	Wi-Fi (Main): Vertical & Horizontal Cross Polarised Wi-Fi (Aux): ±45° Cross Polarised
Path to Ground:	Yes

Electrical Specifications - GPS/Glonass

Frequency Range (GPS):	1575.42MHz/1600MHz
Gain (Max):	21+/-2dBi
VSWR:	≤1.5:1
DC Voltage:	2.7-3.3 V
DC Current:	5-15mA
Noise Figure:	≤1.5 dB
Nominal Impedance:	50 Ω
Polarisation:	RHCP
Filter Out Band Attenuation:	12dB Min f0+50MHz, 16dBi Min f0-50MHz
Voltage:	2.7 - 3.3V
Max. Power:	50 W
Coax Cable Loss:	0.71 dB/m @ 1500 MHz

Product Box Contents

Antenna:	A-EPNT-0004-V1
----------	----------------

Mechanical Specifications

Product Dimensions:	351 mm x 238 mm x 182 mm
Maximum Router Dimensions:	140 mm x 120 mm x 50 mm
Packaged Dimensions:	405 mm x 280 mm x 200 mm
Radome Material:	UV Stable ASA
Radome Colour:	Brilliant White Pantone P 179-1C
Mounting Type:	Wall/ Pole and Surface Mounted

Environmental Specifications, Certification & Approvals

Antenna Wind Survival:	≤220 km/h
Included Bracket Wind Survival:	≤190 km/h
Optional Bracket/Surface Mount Wind Survival:	≤220 km/h
Temperature Range (Operating):	-40°C to +80°C
Environmental Conditions:	Outdoor/Indoor
Ingress Protection:	IP67
Salt Spray:	MIL-STD 810G/ASTM B117
Operating Relative Humidity:	Up to 98%
Storage Humidity:	5% to 95% - non-condensing
Storage Temperature:	-40°C to +80°C
Enclosure Flammability Rating:	UL 94-HB
Impact Resistance:	IK 10
Product Safety & Environmental:	Complies with CE and RoHS standards

**Routers/Router boards have their own operating temperatures as provided in their individual data sheets. Routers/router boards mounted within an EPNT-4 which is exposed to solar radiation will operate at 10-12°C above ambient temperature. Please take this into consideration and select your device to be used with the EPNT-4 accordingly.*



Antenna Performance Plots - Cellular

VSWR: Cellular Antenna

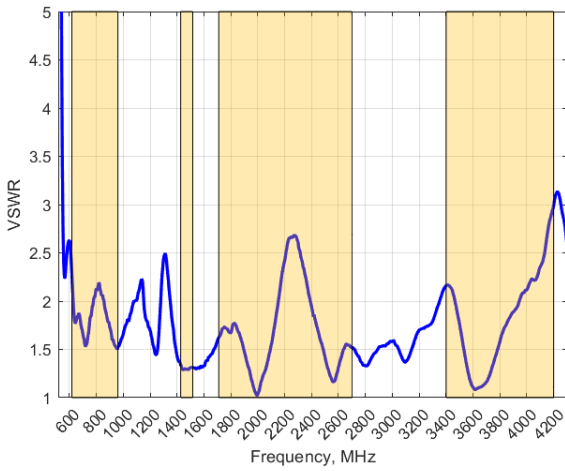

Voltage Standing Wave Ratio (VSWR)*

VSWR is a measure of how efficiently radio-frequency power is transmitted from a power source, through a transmission line, into a load. In an ideal system, 100% of the energy is transmitted which corresponds to a VSWR of 1:1.

The EPNT-4 delivers superior performance across all bands with a VSWR of <3:1.

*VSWR measured without a cable.

VSWR: Wi-Fi Antenna

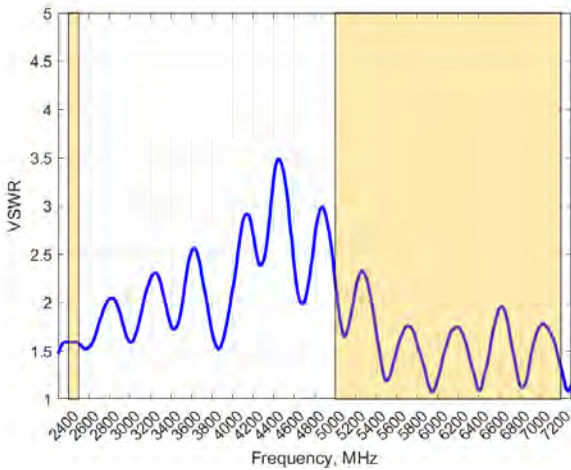

Voltage Standing Wave Ratio (VSWR)*

VSWR is a measure of how efficiently radio-frequency power is transmitted from a power source, through a transmission line, into a load. In an ideal system, 100% of the energy is transmitted which corresponds to a VSWR of 1:1.

The EPNT-4 delivers superior performance across all bands with a VSWR of <2.5:1.

*VSWR measured without a cable.

GAIN (EXCLUDING CABLE LOSS): Cellular Antenna

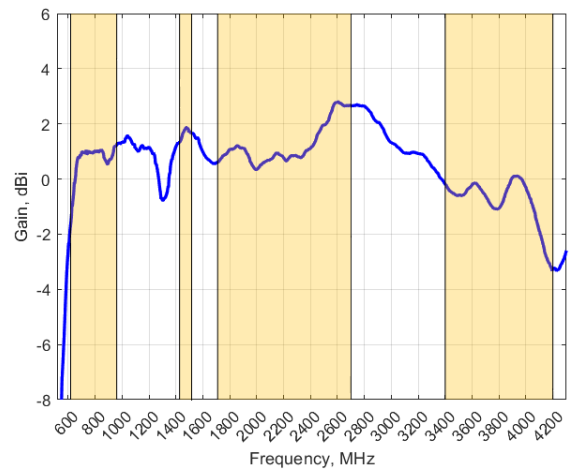

Gain* in dBi

3 dBi is the peak gain across all bands from 617 – 4200 MHz

Gain @ 617 – 960 MHz:	1 dBi
Gain @ 1427 – 1517 MHz:	2 dBi
Gain @ 1710 – 2700 MHz:	3 dBi
Gain @ 3400 – 4200 MHz:	0 dBi

*Antenna gain measured with polarisation aligned standard antenna

GAIN (EXCLUDING CABLE LOSS): Wi-Fi Antenna

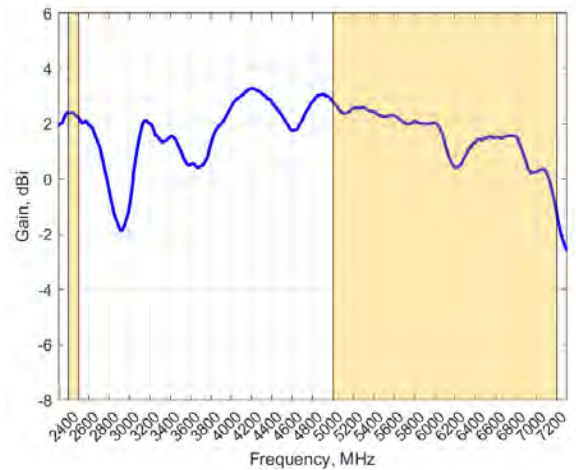

Gain* in dBi

2.2 dBi is the peak gain across all bands from 2400 – 2500 MHz and 5000 – 7200 MHz

Gain @ 2400 - 2500 MHz:	2.2 dBi
Gain @ 5000 – 7200 MHz:	2.2 dBi

*Antenna gain measured with polarisation aligned standard antenna

Technical Drawings

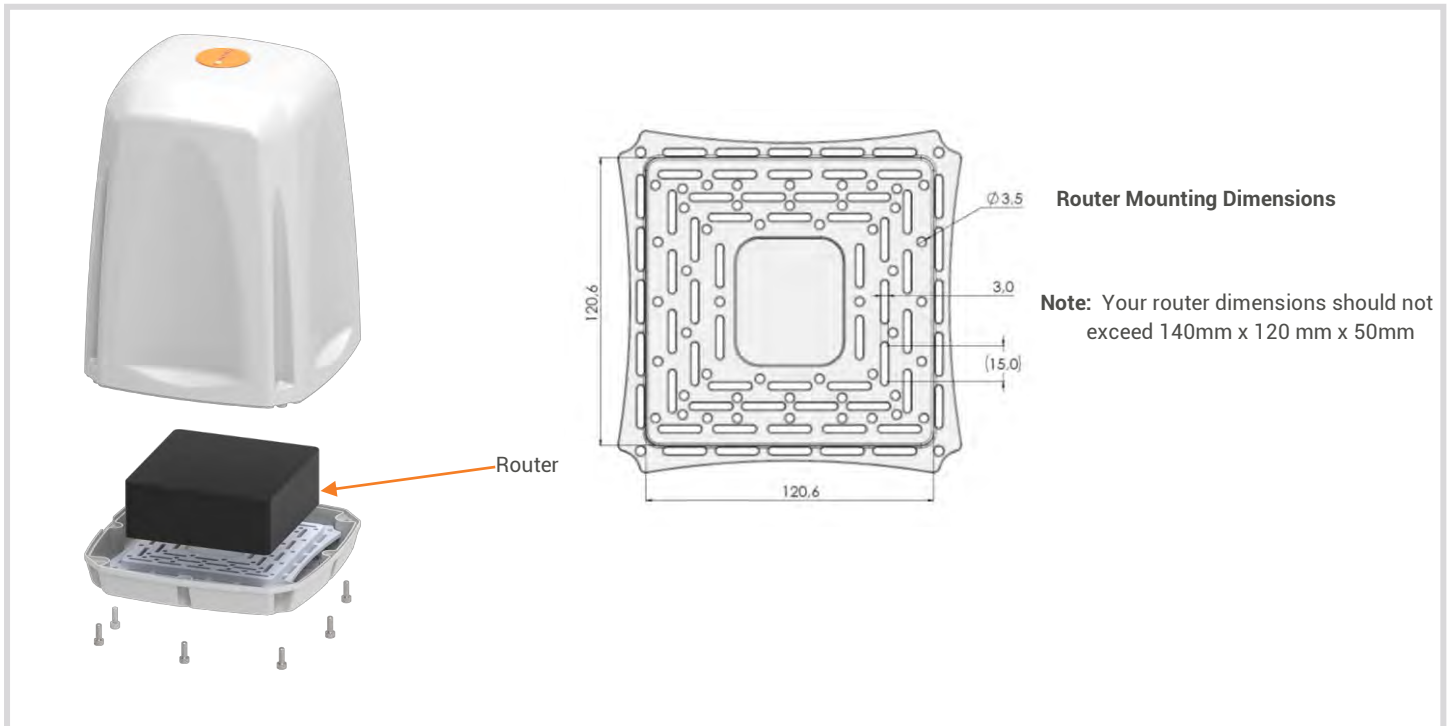
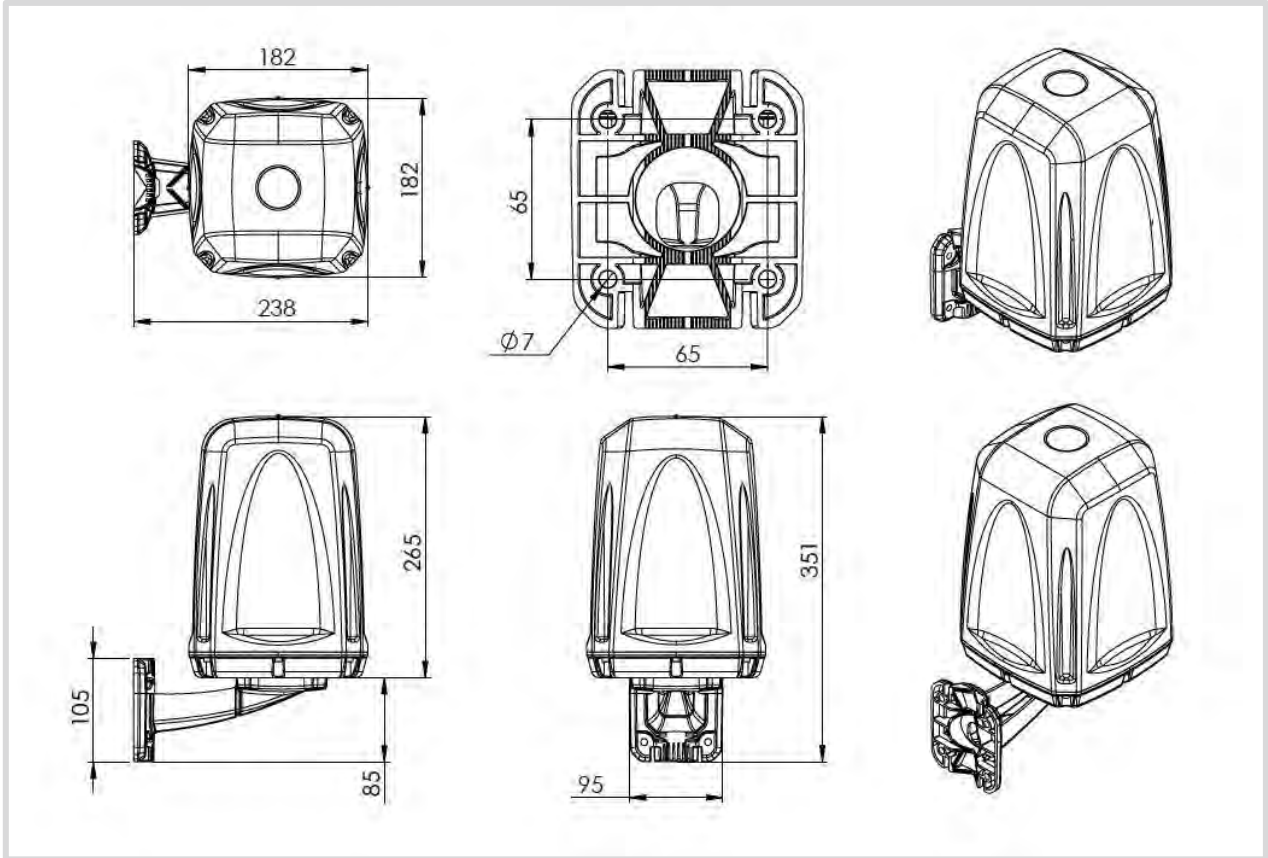

Radiation Patterns – Cellular

Azimuth: 617 – 960 MHz

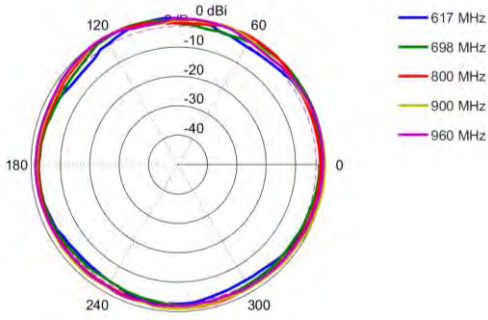

Azimuth: 1427 – 1517 MHz

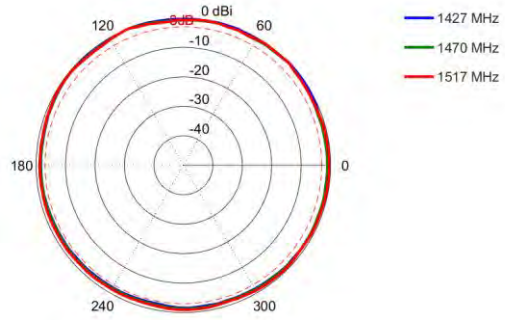

Azimuth: 1710 – 2100 MHz

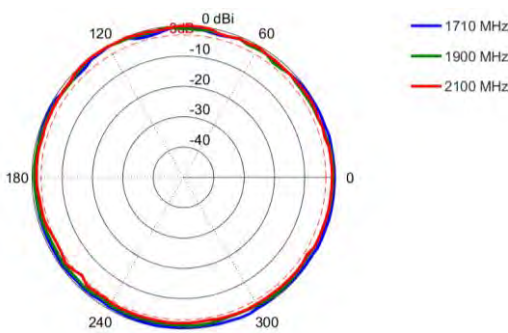

Azimuth: 2300 – 2700 MHz

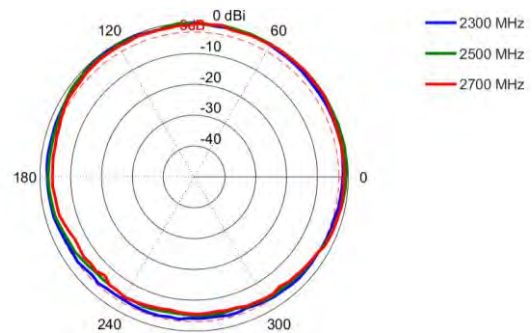

Azimuth: 3400 – 3800 MHz

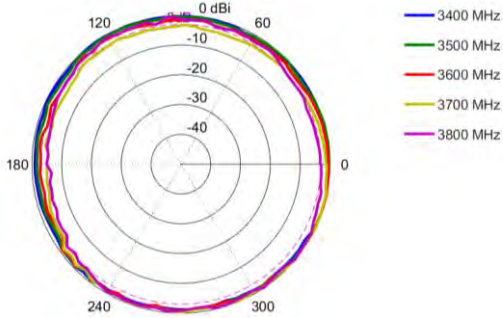

Azimuth: 4000 – 4200 MHz

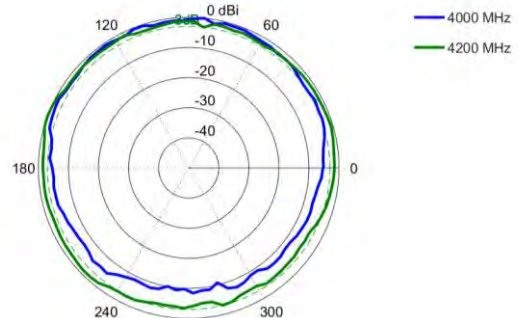

Elevation: 617 – 960 MHz

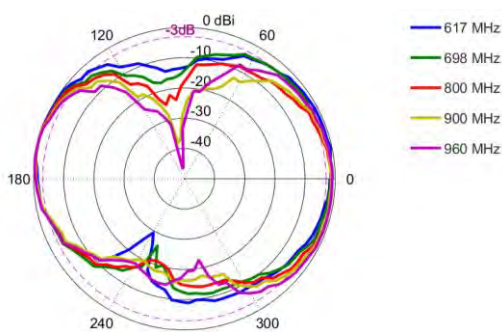

Elevation: 1427 – 1517 MHz

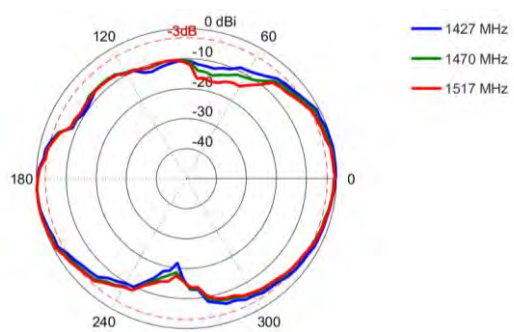

Elevation: 1710 – 2100 MHz

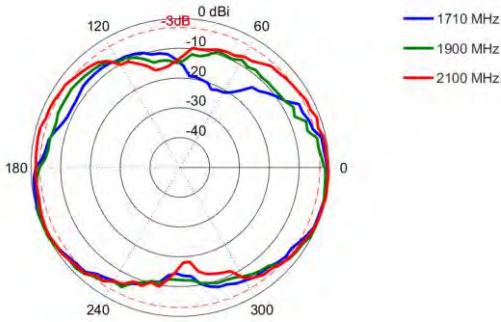

Elevation: 2300 – 2700 MHz

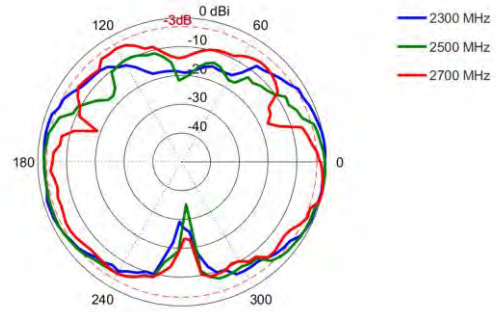

Elevation: 3400 – 3700 MHz

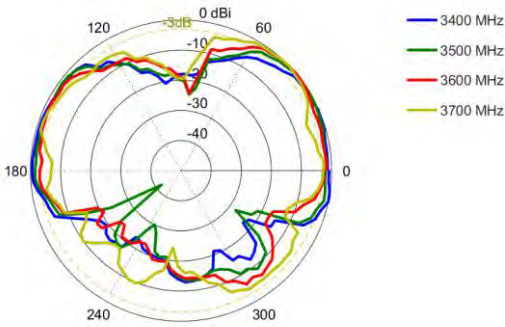

Elevation: 4000 – 4200 MHz

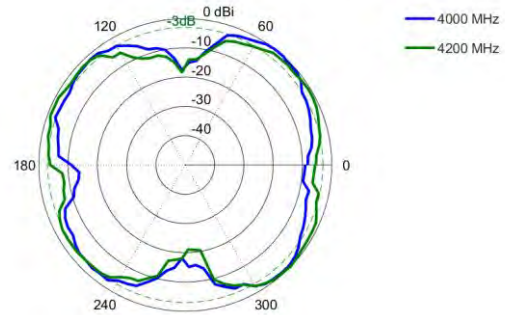

Radiation Patterns – Wi-Fi

Azimuth: 2400 – 2500 MHz

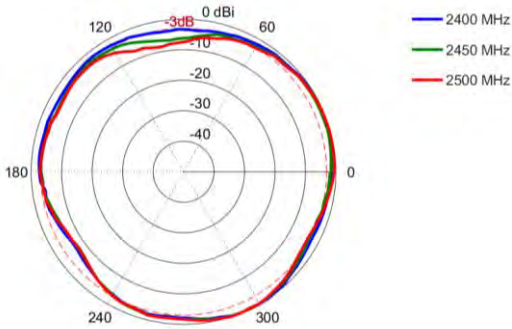

Azimuth: 5000 – 6000 MHz

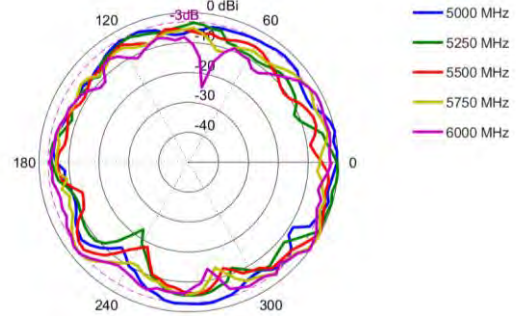

Azimuth: 6300 – 7200 MHz

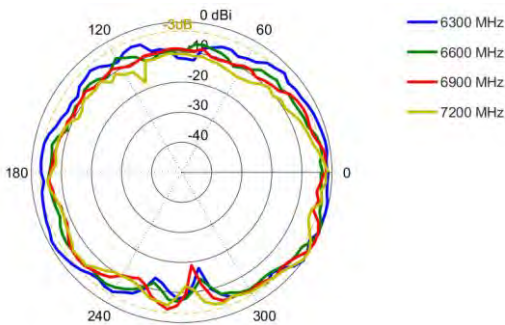

Elevation: 2400 – 2500 MHz

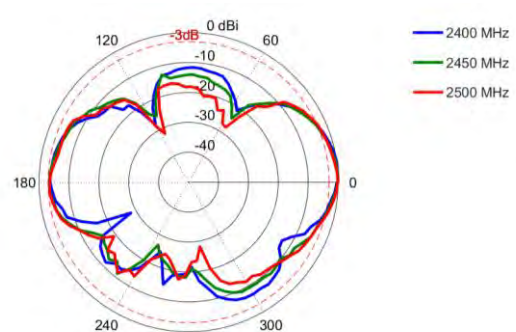

Elevation: 5000 - 6000 MHz

Elevation: 6300 - 7200 MHz

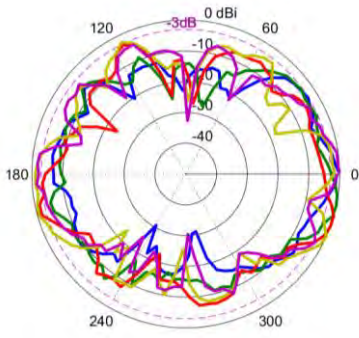

- 5000 MHz
- 5250 MHz
- 5500 MHz
- 5750 MHz
- 6000 MHz

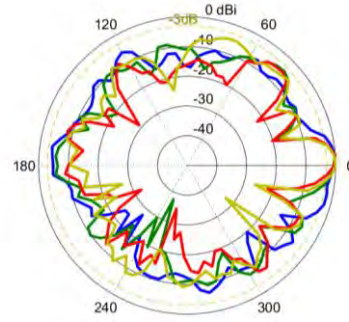

- 6300 MHz
- 6600 MHz
- 6900 MHz
- 7200 MHz

Mounting Options

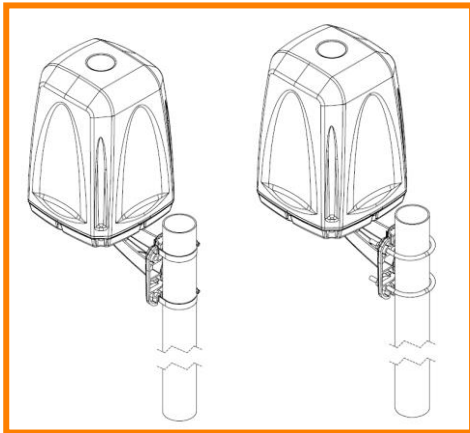

Pole Mount

Pole mounting using U-bolts or pipe clamps (included)

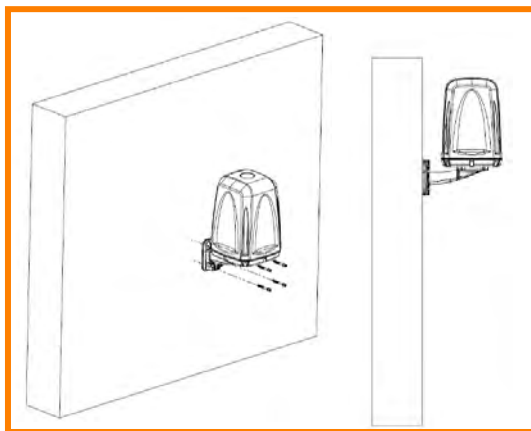

Wall Mount

Wall mounting using knock-in screws (included)

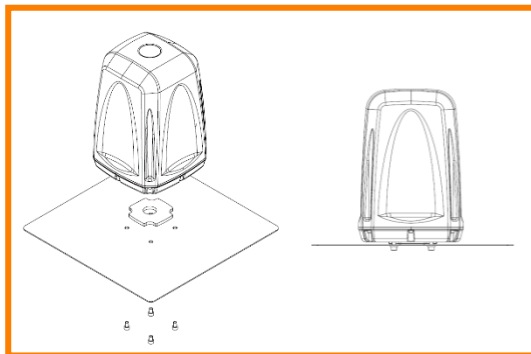

Surface Mount

Surface mounting using a surface mount gasket (included)

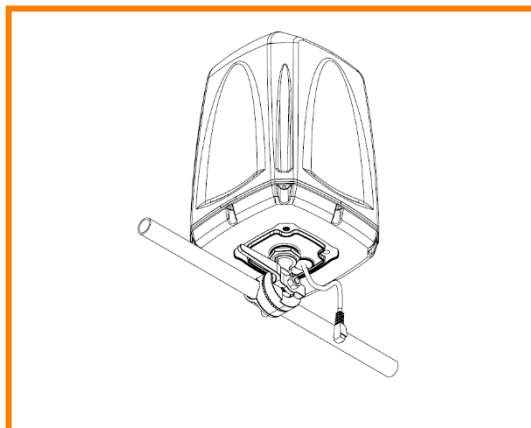

Marine Mount

Surface mounting using optional marine bracket (BRKT-038) and MISC 103 Kit – Not included

Additional Accessories



Optional BRKT-38-V1-01 (Not Provided)

Marine ratchet rail mount antenna bracket 1"-14TPI 316 Stainless Steel

Contact USAT to Order



USAT LLC
605 Eastowne Drive
Chapel Hill, NC 27514

Phone: (888) 550-8728
Email: info@usatcorp.com
Web: <https://usatcorp.com>

CONTACT POYNTING

Poynting Antennas (Pty) Ltd - Head Office

Unit 4, N1 Industrial Park,
Landmarks Avenue,
Samrand, 0157, South Africa

Phone: +27 (0) 12 657 0050

E-mail: info@poynting.tech

International Email: sales-global@poynting.tech

Poynting Europe

Regus Business Center Neue Messe Riem
Kronstadter Straße 4
81677 München
Germany

Phone: +49 89 7453 9002

E-mail: sales-europe@poynting.tech

Poynting USA

1804 Owen Court, Suite 104,
Mansfield,
TX 76063
USA

Phone: +1 817 533-8130

E-mail: sales-us@poynting.tech