

BRACKET | PY-BRKT-030

BRKT-030

LPDA 92 LTE HORIZONTAL MOUNTING BRACKET

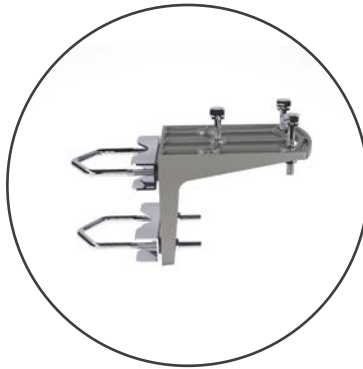

Ordering Information

Commercial name: BRKT-030
 Order Product Code: PY-BRKT-030
 EAN Number: 6009693810112

Mechanical Specifications

Product dimensions (L x W x D): 127 x 100 x 97mm
 Packaged Dimensions (L x W x D): 150 x 120 x 120mm
 Weight: 0.337kg
 Packaged Weight: 0.396kg
 Material: Cast Aluminium ADC12
 Process: Cast Item
 Surface finish: Die Cast 1.6 - 0.8 µm

Product Drawing

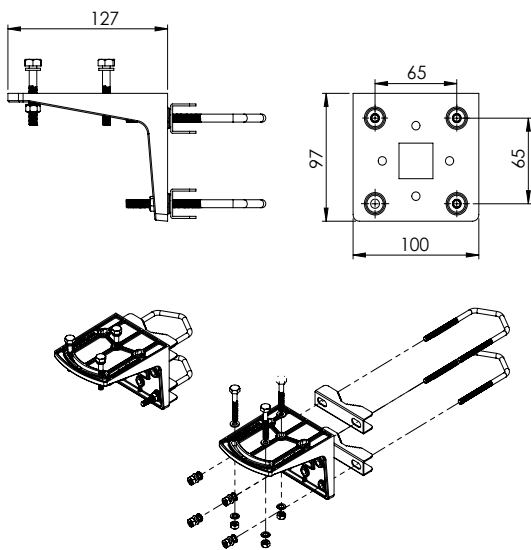

Product Box Contents

Product: A-BRKT-030
 M6 nylock nut ss: 3
 M6 flat washer ss: 6
 M6x40mm bolt ss: 3

Certification Approvals and Standards

Flammability rating: UL:1581
 Salt spray: MIL-STD810F/ASTM B117
 Product Safety: Complies with CE and RoHS standards

Contact Us

USAT | Connect What's Critical™

605 Eastowne Drive
 Chapel Hill, NC 27514

Phone: (919) 942-4212
E-mail: info@usatcorp.com
Web: https://usatcorp.com

