

ANTENNAS | OMNI-296 SERIES

## OMNI-DIRECTIONAL, DUAL-BAND WI-FI ANTENNA

2400 - 2500 MHz, 3400 - 3800 MHz & 5000 - 6000 MHz, 7.5 dBi



2400 – 2500 MHz; 3400 – 3800 MHz; 5000 – 6000 MHz	7.5 dBi	Increase x Mb/s	Omni- Directional	2.4 - 2.5 GHz 5.0 - 6.0 GHz	CBRS Band	5G Ready
IoT	Machine to Machine	IP 65	-40°C to +70°C	Fire Resistant		

- Dual-band 2.4 GHz and 5 GHz Wi-Fi antenna
- Omni-directional antenna with medium gain
- Complaint with IEEE 802.11b/g/n and 802.11ac wireless standard
- Covers the 3.5 GHz CBRS band for future 5G applications
- Vandal and water-resistant enclosure (IP 65)

APPLICATION AREAS

Urban

Rural/Farm

### Product Overview

The OMNI-296 antenna is a dual-band Wi-Fi omni-directional antenna, developed by Poynting Antennas. The antenna can connect to any Wi-Fi access point whether it is older Wi-Fi technology or new dual band Wi-Fi technology. The antenna can therefore be used to resolve channel saturation and provide the ultimate in Wi-Fi performance and flexibility. This means that the antenna can also be used for point to point links where there is abundance of RF noise and cluttered environments.

The antenna operates in the two Wi-Fi frequency bands (2.4 GHz and 5 GHz), offering excellent utilization of the radio spectrum. The antenna has a maximum gain of 6dBi in the 2.4GHz band and 7.5dBi in the 5GHz band, which offers the best performance with reliable connections. The antenna also covers the 3.5 GHz CBRS band, which will be used for future 5G technologies with a peak gain of 7dBi. The housing is made of ABS which is a high impact resistant plastic and is also resistant to acids and other chemicals that may occur in industrial plants. The antenna has an N-Type female connector at its base which can be connected to a cable of the desired type and length.

### Features

- Dual-band Wi-Fi antenna for 2.4 GHz and 5 GHz
- Medium gain omni-directional antenna
- Covers 3.5 GHz CBRS band for future 5G applications
- Robust and weather resistant
- Lightweight design

### Application Areas

- Small business
- Building sites and open cast mines
- Production facilities and factories
- M2M and IoT applications
- Areas with large amounts of machinery (cluttered environments)



### Frequency Bands

The OMNI-296 is an omni-directional antenna that works from 2400 – 2500 MHz | 3400 – 3800 MHz | 5000 – 6000 MHz

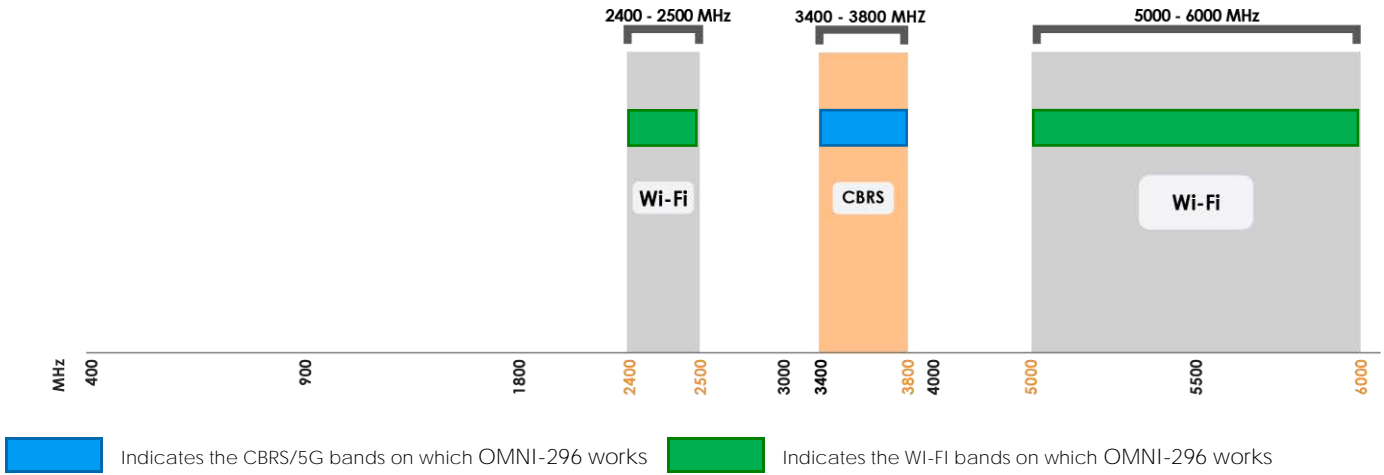

### Antenna Overview

Ports	1
SISO / MIMO	SISO
Frequency Bands	2400 – 2500 MHz, 3400 – 3800 MHz 5000 – 6000 MHz
Polarisation	Linear Vertical
Peak Gain	7.5 dBi
Coax Cable Type	N/A
Coax Cable Length	N/A
Connector Type	N-Type (F)

## Electrical Specifications

Frequency bands:	2400 – 2500 MHz 3400 – 3800 MHz 5000 – 6000 MHz
Gain (max):	6 dBi @ 2400-2500 MHz 7 dBi @ 3400-3800 MHz 7.5 dBi @ 5000-6000 MHz
VSWR:	<2.5:1
Feed power handling:	10 W
Input impedance:	50 Ohm (nominal)
Polarisation:	Linear Vertical
DC short:	Yes

## Product Box Contents

Antenna:	A-OMNI-0296-V1
Mounting bracket:	Pole up to 50mm diameter wall and Pole mount stainless steel bracket

## Ordering Information

Commercial name:	OMNI-296-V1
Order product code:	A-OMNI-0296-V1
EAN number:	0707273469694

## Mechanical Specifications

Product dimensions	485 mm x Ø71 mm (excl. bracket)
Packaged dimensions:	510 mm x 95 mm x 95 mm
Weight:	0.75 kg
Packaged weight:	0.91 kg
Radome material:	ABS (Halogen Free)
Radome colour:	Pantone - Cool Gray (1c)
Mounting Type:	Pole and Wall

## Environmental Specifications, Certification & Approvals

Wind Survival:	≤190 km/h
Temperature Range (Operating):	-40°C to +70°C
Environmental Conditions:	Outdoor/Indoor
Water ingress protection ratio/standard:	IP 65
Salt Spray:	MIL-STD 810F/ASTM B117
Operating Relative Humidity:	Up to 98%
Storage Humidity:	5% to 95% - non-condensing
Storage Temperature:	-40°C to +70°C
Enclosure Flammability Rating:	UL 94-HB
Impact resistance:	IK 08
Product Safety & Environmental:	Complies with CE and RoHS standards



Antenna Performance Plots

VSWR

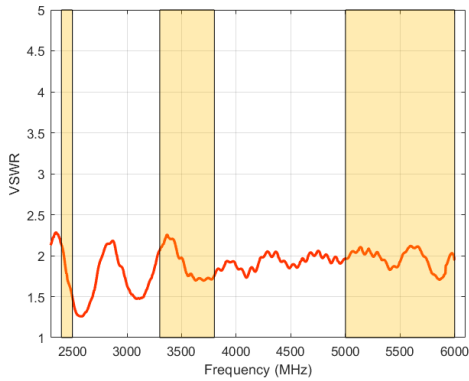

GAIN (EXCLUDING CABLE LOSS)

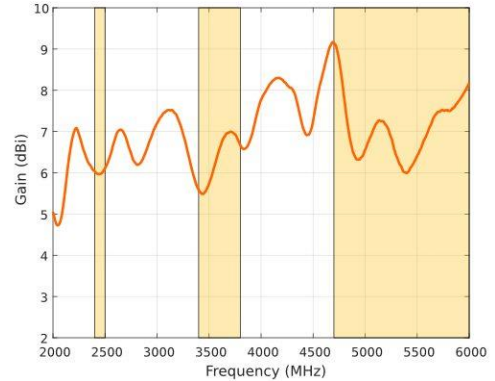

Voltage Standing Wave Ratio (VSWR)

VSWR is a measure of how efficiently radio-frequency power is transmitted from a power source, through a transmission line, into a load. In an ideal system, 100% of the energy is transmitted which corresponds to a VSWR of 1:1.

The OMNI-296 delivers superior performance across all bands with a VSWR of 2.5:1 or better.

Gain\* in dBi

7.5 dBi is the peak gain across all bands from 2400 – 6000 MHz

Gain @ 2400 – 2500 MHz:	6 dBi
Gain @ 3400 – 3800 MHz:	7 dBi
Gain @ 5000 – 6000 MHz:	7.5 dBi

\*Antenna gain measured with polarisation aligned standard antenna

Technical Drawings

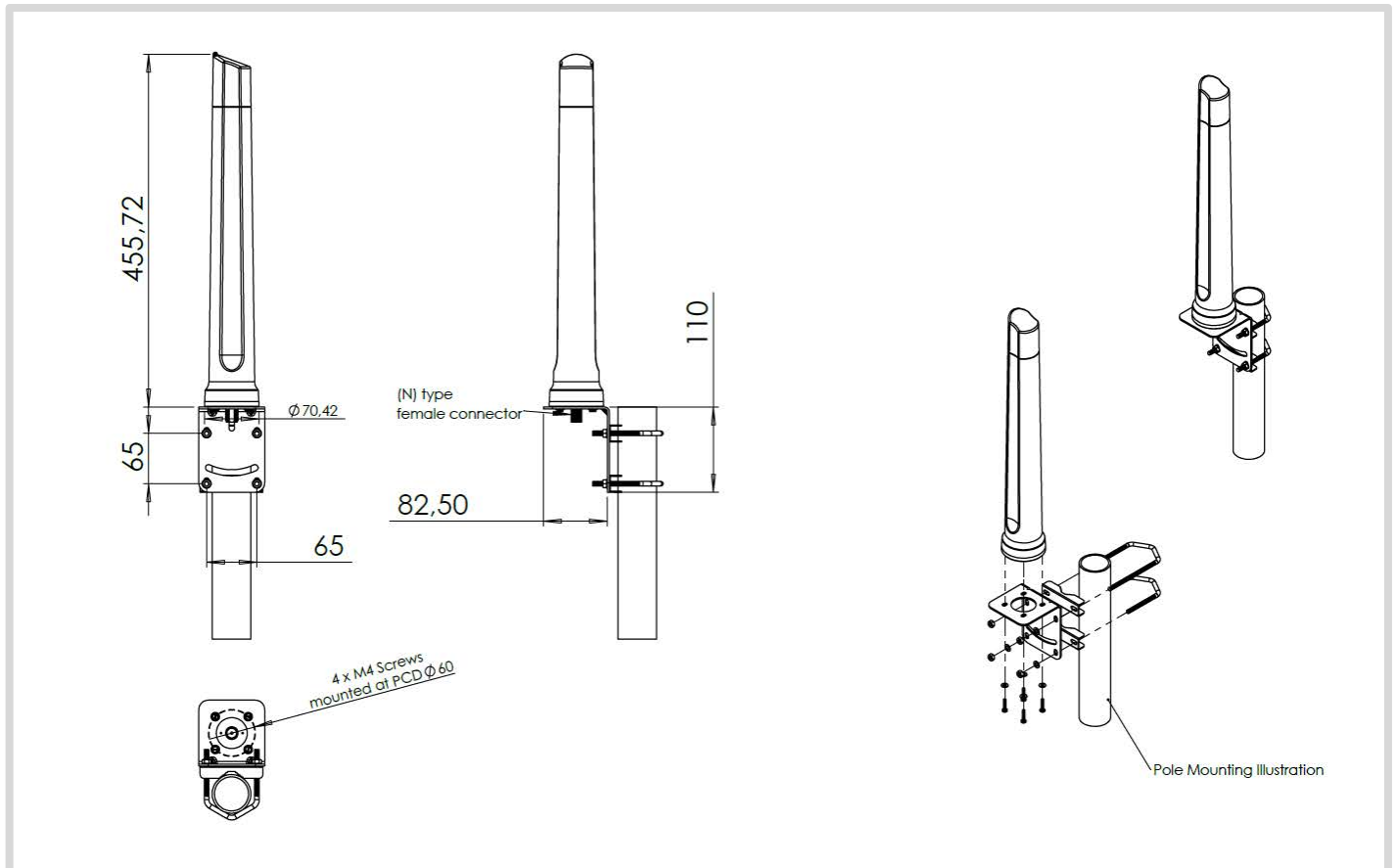

Radiation Patterns

Azimuth: 2400 – 2500 MHz      Azimuth: 3400 – 3800 MHz

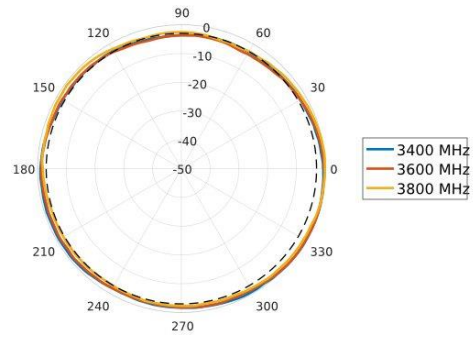
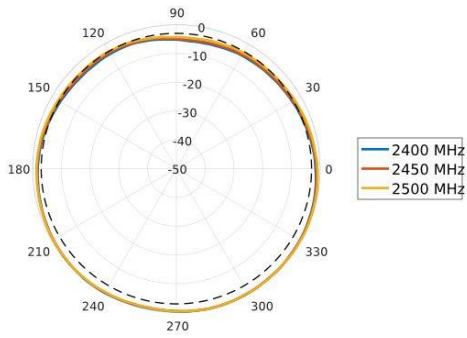

Azimuth: 5000 – 6000 MHz      Elevation: 2400 – 2500 MHz

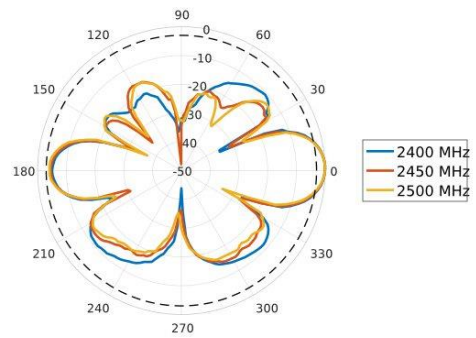
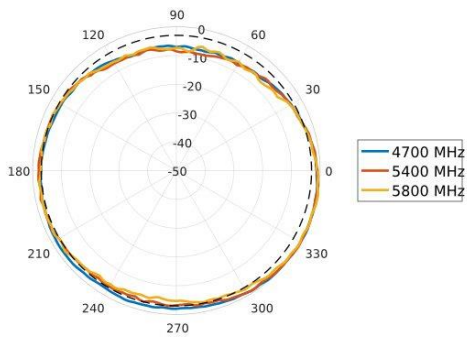

Elevation: 3400 – 3800 MHz      Elevation: 5000 – 6000 MHz

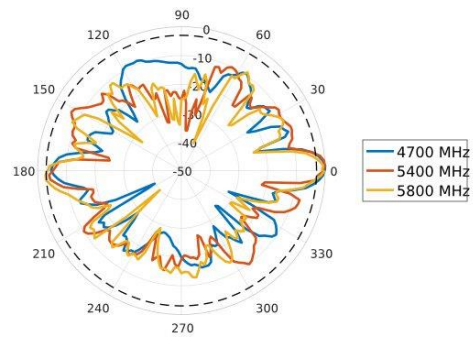
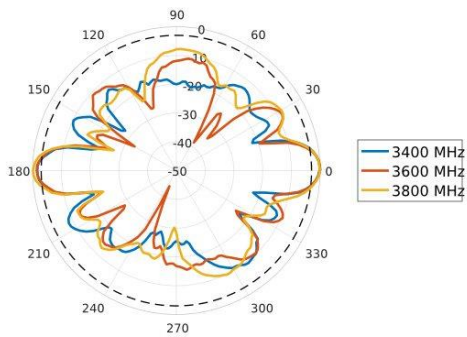

Mounting Options

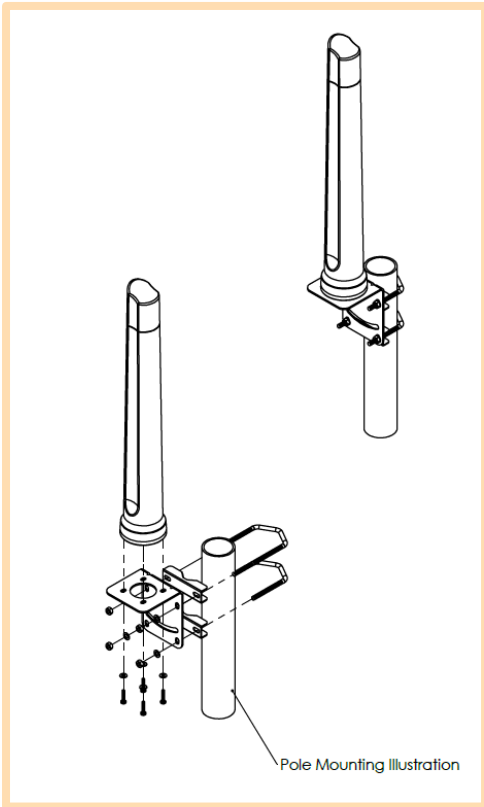

Pole Mount

Pole/Wall Mounting bracket (included)

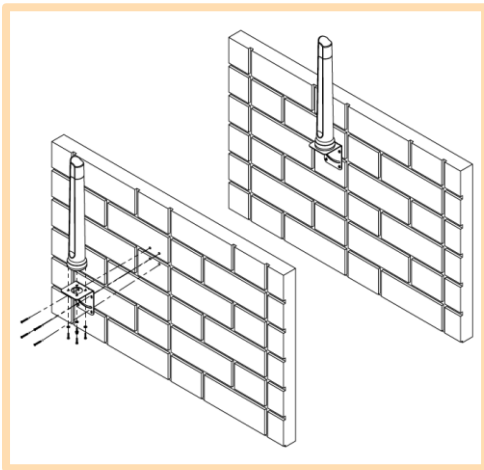

Wall Mount

Pole/Wall Mounting bracket (included)

---

## Additional Accessories

Extension Cables: Up to 15m HDF 195  
Various connectors available  
Installation poles and brackets available

See accessories technical specifications on [www.poynting.tech](http://www.poynting.tech)

## Contact Us

---

**USAT | Connect What's Critical™**

605 Eastowne Drive  
Chapel Hill, NC 27514

Phone: (919) 942-4214

E-mail: [info@usatcorp.com](mailto:info@usatcorp.com)

**Web:** <https://usatcorp.com>