

ANTENNAS | HELI-6 SERIES

CIRCULAR POLARISED, DIRECTIONAL MINE/TUNNEL ANTENNA

LTE/LoRa; 690 - 960 MHz, 13.5 dBi



690 - 960 MHz	13.5 dBi	Increase x Mb/s	Uni-Directional	Machine to Machine	Internet of Things
4G LTE	LoRa	IP 65	-40°C to +70°C	Fire Resistant	

- Circular Polarised HELI antenna provides enhanced signal propagation and connection stability within a tunnel
- Covers traditional ISM bands for 868/915 MHz, LoRa and other technologies
- Left Hand Circular (LHC) polarised
- Uni-directional – radiates in one direction in a tunnel
- Ruggedized & water ingress protected (IP 65)
- Ideal for Mining & Tunnel M2M and IoT deployments



Mining



Tunnelling



Mining and Surface

APPLICATION AREAS

Product Overview

The HELI-6 is a high gain LTE directional antenna, which complements our MinePoynt mine and tunnel antennas. MinePoynt antennas exploits Poynting's fifteen years' experience in designing and manufacturing antennas for underground mining communication and data networks. This antenna is also suitable for oil/gas chemical environments as well as fiery mines where IS equipment is required. In tests, the data rate and range achieved with this antenna was substantially greater than obtained when using linear polarised panel antennas of the same gain. The hardy construction of the antenna makes it ideal for a mining environment.

Features

- High gain over the 690 – 960 MHz frequency range
- Uni-directional antenna
- Proven antenna performance giving maximum range
- Improved performance due to circularly polarised
- Ideal for mining and tunnelling applications
- Intrinsically safe version available on request

Application Areas

- Supplementing fibre/cable network "Hotspots" to enhance mobility or extend networks to inaccessible areas such as mines and tunnels
- Underground telemetry
- Creation of complete underground in-tunnel wide data networks and internet/LTE connectivity
- Seamless connection to personnel using cellular phones, smart devices and tablets



Frequency Bands

The HELI-6 is a Lora/LTE antenna that works from 690 - 960 MHz

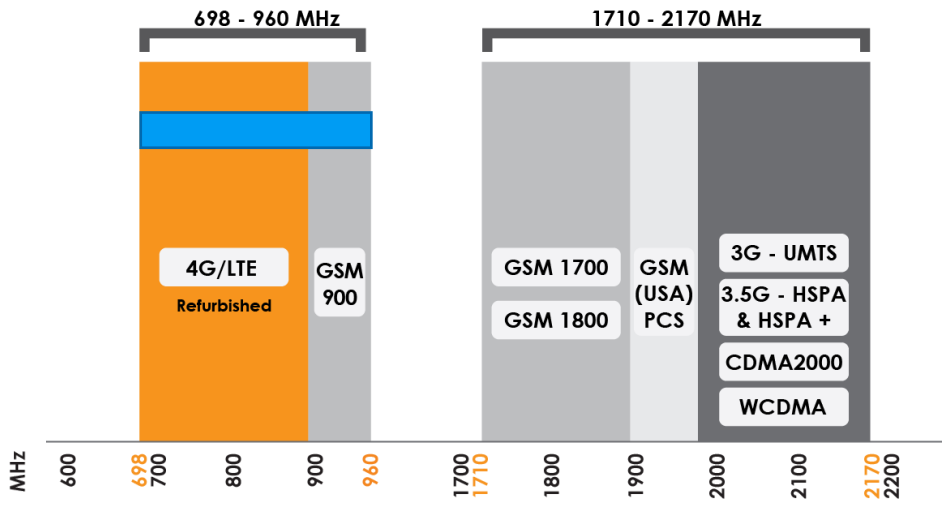

Indicates the LTE bands on which HELI-6 works

Antenna Overview

Ports	1
SISO / MIMO	SISO
Frequency Bands	690 – 960 MHz
Polarisation	Left Hand Circular Polarised
Peak Gain	13.5 dBi
Coax Cable Type	N/A
Coax Cable Length	N/A
Connector Type	N-Type (Female) Bulkhead

Electrical Specifications

Frequency bands:	690 - 960 MHz
Gain (max):	13.5 dBi
VSWR:	<2:1 over 90% of the band
Feed power handling:	30 W
Input impedance:	50 Ohm (nominal)
Polarisation:	LHC <i>*RHC option available upon request</i>
Coax cable loss:	N/A
DC short:	No

Coax Cable & Connector Type

Cable length:	N/A
Coax cable type:	N/A
Connector type:	N-Type (Female) Bulkhead <i>*The connector is factory mounted to the antenna</i>

Product Box Contents

Antenna:	A-HELI-0006-V1-01
Mounting bracket:	65mm U-bolt for pole mount option

Ordering Information

Commercial name:	HELI-6
Order product code:	A-HELI-0006-V1-01
EAN number:	6009880915453

Mechanical Specifications

Product dimensions	705 mm x 245 mm x 197 mm
Packaged dimensions:	750 mm x 250 mm x 210 mm
Weight:	4.20 kg
Packaged weight:	4.45 kg
Radome material:	PVC
Radome colour:	Grey
Mounting Type:	Ceiling Mount (12mm ID Eye Hook) Pole Mount (65mm U-bolt)

Environmental Specifications, Certification & Approvals

Wind Survival:	≤120 km/h
Temperature Range (Operating):	-40°C to +70°C
Environmental Conditions:	Outdoor/Indoor
Water ingress protection ratio/standard:	IP 65
Salt Spray:	MIL-STD 810G/ASTM B117
Operating Relative Humidity:	Up to 98%
Storage Humidity:	5% to 95% - non-condensing
Storage Temperature:	-40°C to +70°C
Enclosure Flammability Rating:	UL 94-HB
Impact resistance:	IK 08
Product Safety & Environmental:	Complies with CE and RoHS standards

Antenna Performance Plots

VSWR

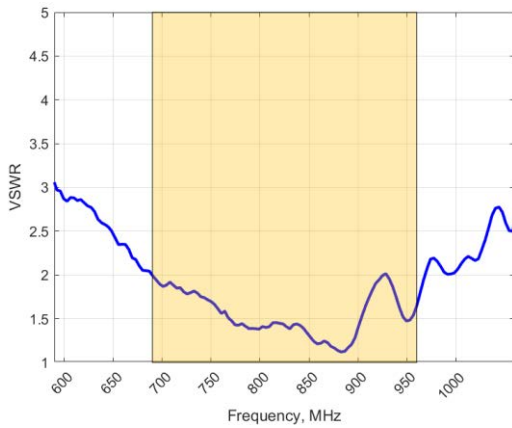

GAIN (EXCLUDING CABLE LOSS)

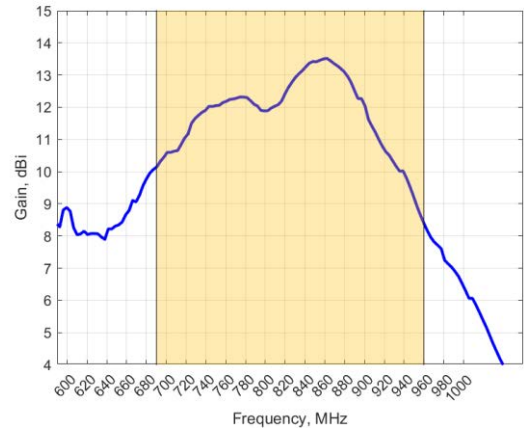

Voltage Standing Wave Ratio (VSWR)

VSWR is a measure of how efficiently radio-frequency power is transmitted from a power source, through a transmission line, into a load. In an ideal system, 100% of the energy is transmitted which corresponds to a VSWR of 1:1.

The HELI-6 delivers superior performance across all bands with a VSWR of 2:1 or better across 90% of the bands.

Gain* in dBi

13.5 dBi is the peak gain across all bands from 690 – 960 MHz

Gain @ 690 - 960 MHz:

13.5 dBi

*Antenna gain measured with polarisation aligned standard antenna

Technical Drawings

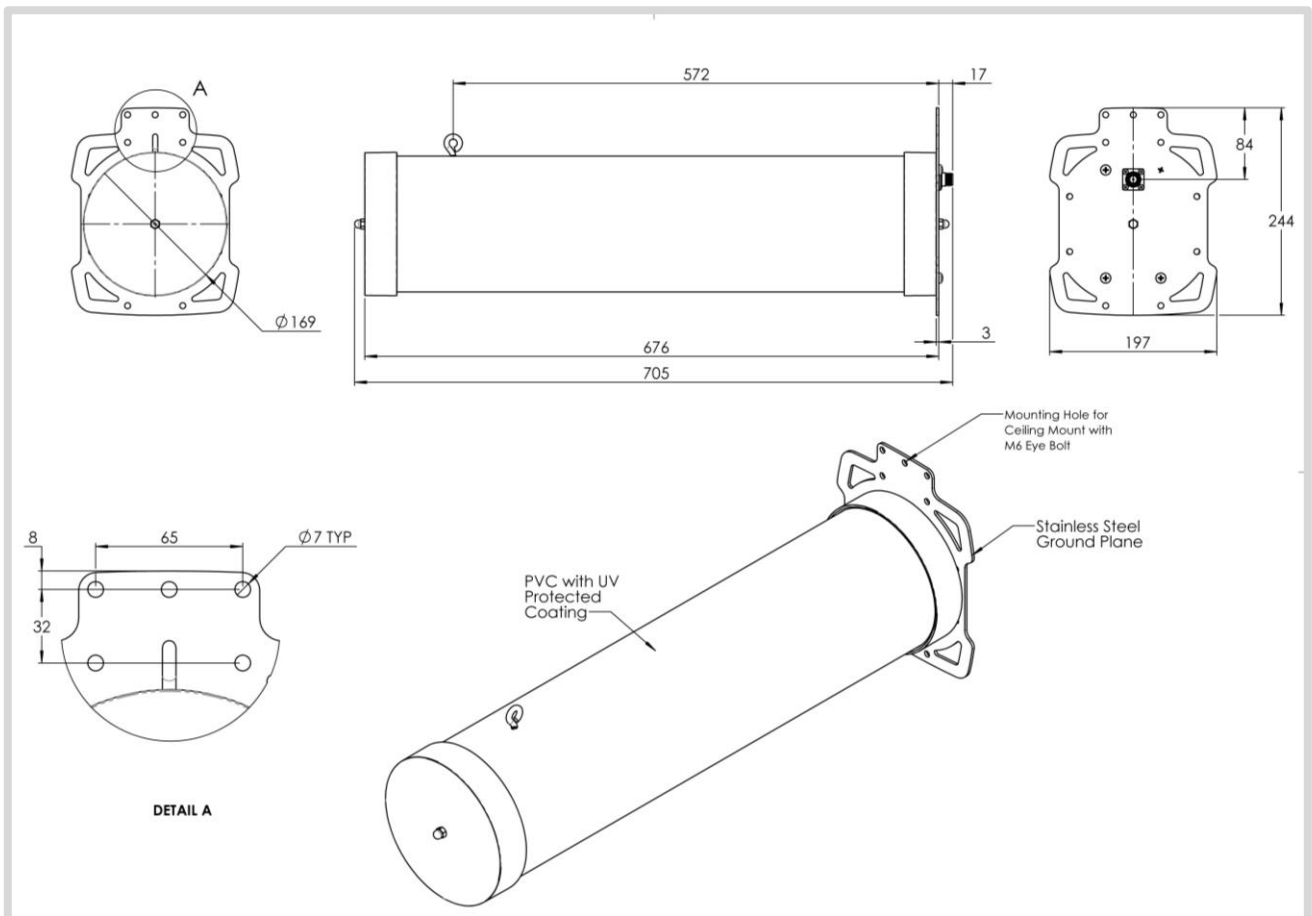

Radiation Patterns

Azimuth: 690 - 960 MHz

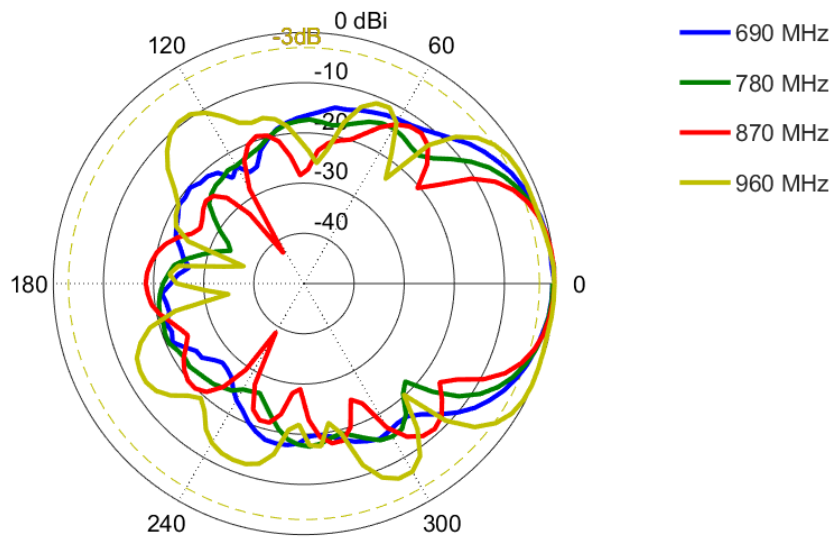

Elevation: 690 - 960 MHz

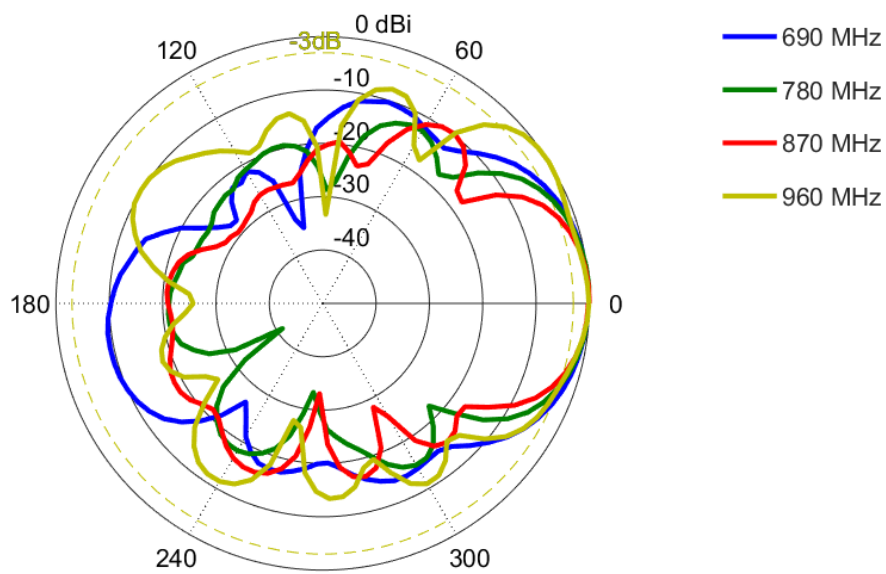

Mounting Options

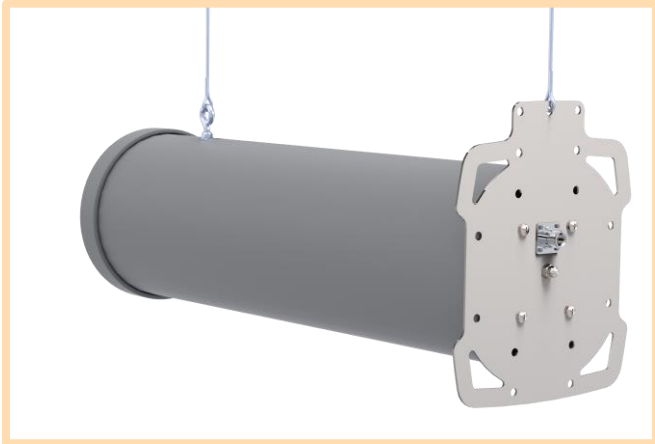

Ceiling Mount

Suspend from ceiling to desired height with cable attached to the M6 eye bolt and one of the mounting holes on the ground plate.

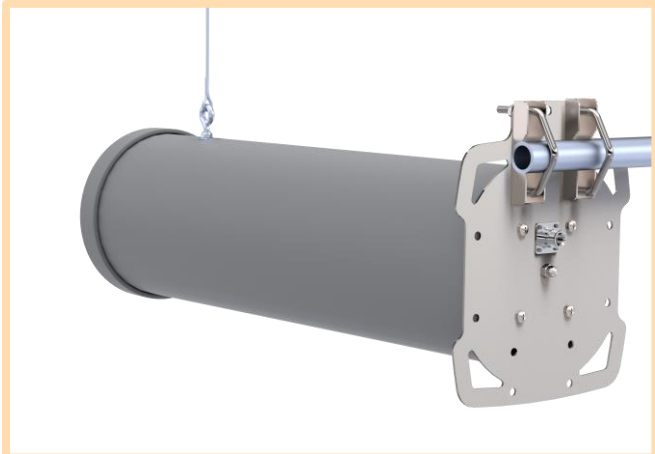

Pole/Hanger Bolt Mount

Suspend from ceiling using the eye bolt and attaching the ground plane to a pole or hanger bolt using the included u-bolts.

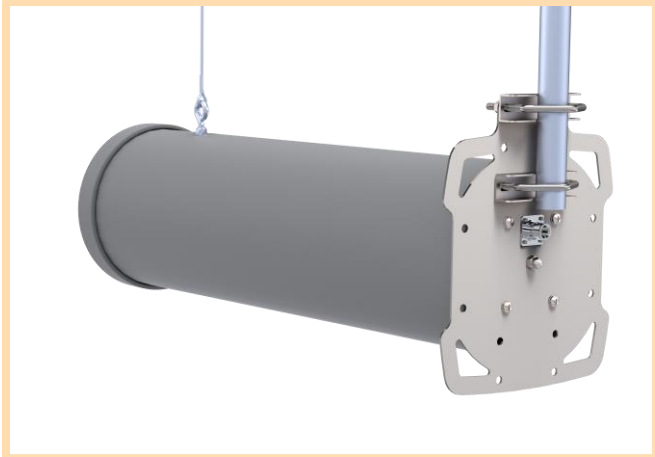

Contact Us

USAT | Connect What's Critical™

605 Eastowne Drive
Chapel Hill, NC 27514

Phone: (919) 942-4214

E-mail: info@usatcorp.com

Web: <https://usatcorp.com>